

***TM 10-1670-305-23&P
AIRFORCE T.O. 14D2-11-1
NAVSEA SS400-AY-MMO-010
MARINE CORPS TM 1670-23&P**

TECHNICAL MANUAL

**UNIT AND DIRECT SUPPORT MAINTENANCE MANUAL
(INCLUDING REPAIR PARTS AND SPECIAL TOOLS LISTS)**

AUTOMATIC RIPCORD RELEASE, AR2, MODEL 451

NSN 1670-01-369-7914

TEST CHAMBER ASSEMBLY, AR2, MODEL 452

NSN 1670-01-370-0752

ELECTRONIC TEST CHAMBER ASSEMBLY, AR2, MODEL 453

NSN 1670-01-468-9471

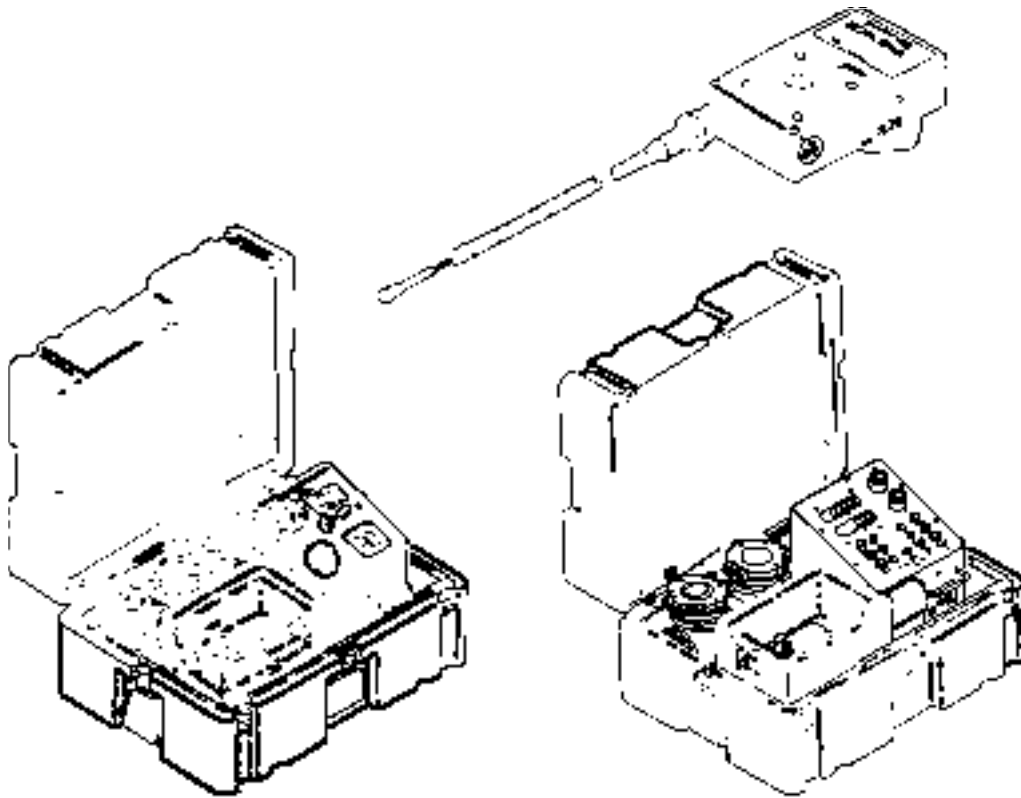

3 10 0000 P

DISTRIBUTION STATEMENT A: Approved for public release; distribution is unlimited.

*This manual supersedes TM 10-1670-305-13&P, dated 30 JUNE 1995

HEADQUARTERS, DEPARTMENT OF THE ARMY

21 JUNE 2000

PCN 182 019003 00

THIS PAGE INTENTIONALLY LEFT BLANK

WARNING SUMMARY

This warning summary includes general safety precautions and instructions that must be understood and applied during the operation and maintenance of this system/equipment to ensure personnel against injury, death, or long-term health hazards. A summary of safety and hazardous material warnings that should be heeded in conduct of operation and maintenance is provided below.

WARNING

When attaching the power cable assembly to the AR2, always verify proper engagement of ball end of power cable with piston rod of AR2 by looking through transparent plastic cable seal retainer. Cable seal retainer and power cable seal must be present to ensure seating of power cable ball. If ball is not engaged with piston rod, or if cable seal retainer is missing, actuation of AR2 will fail to pull ripcord pins, which may result in death of parachutist.

WARNING

If there is any indication of a leak in the aneroid, remove the AR2 from service. A leaking aneroid may cause a malfunction which may result in death of parachutist.

WARNING

The altitude dial indicates thousands of feet above mean sea level (not above ground level). If the altitude dial is incorrectly set, two parachutes may deploy and become entangled, which may result in death of parachutist.

WARNING

Do not move the JUMP/OFF switch to jump unless the (equivalent pressure altitude inside the) aircraft is at least 1,500 feet above the altitude set on the dial. It is imperative that the AR2 remains well above its actuation altitude at all times after the jump/off switch has been moved to jump. If there is a temporary reduction in aircraft altitude, and the AR2 switch is not recycled back to jump after again rising above the actuation altitude, the AR2 will actuate prematurely during the jump, possibly causing deployment of two parachutes which may become entangled, which may result in death of parachutist.

WARNING

When the AR2 is used on the reserve parachute, the main parachute must be activated at an altitude high enough to obtain a fully deployed canopy at least 1,500 feet above the actuation altitude for the AR2. If the main parachute opens within only a few hundred feet of the AR2 actuation altitude, the AR2 may deploy the reserve parachute. The two parachutes may become entangled, which may result in death of parachutist.

WARNING

The JUMP/OFF switch must be set to OFF immediately after every jump. Setting the JUMP/OFF switch to OFF repositions the mechanism for the next jump and prevents inadvertent actuation on the ground or during transport. If the switch is left in JUMP position, the next jump will cause the AR2 to actuate prematurely. Two parachutes may deploy and become entangled, which may result in death of parachutist.

WARNING

Model 452 test chamber and carrying case weighs 70 lbs. The mounting base with attached components weighs 50 lbs. Use two persons or lifting device when lifting to prevent injury to personnel.

WARNING

Model 453 test chamber and carrying case weighs 60 lbs. The mounting base with attached components weighs 42 lbs. Use two persons or lifting device when lifting to prevent injury to personnel.

WARNING

The heads of the air compressor and vacuum pump become hot with use and can cause burns to unprotected skin. Do not touch these components during operation or until they have been allowed to cool down after the test chamber has been switched off.

WARNING

Do not move CLIMB/FALL/COCK switch on test chamber to cock unless AR2 JUMP/OFF switch is in the fully OFF position. Attempting to cock the mechanism with the switch in an intermediate position may damage internal components and render the AR2 inoperative. This will prevent deployment of a parachute and may result in death of parachutist.

WARNING

If malfunctions of the rate of fall mechanism occur, or if actuation altitude deviates from the dial setting by more than the prescribed tolerance, a malfunction may occur, which may result in death of parachutist.

WARNING

Do not open or remove screws of AR2 housing. No internal maintenance is authorized. Unauthorized disassembly may cause a malfunction which may result in death of parachutist.

WARNING

The power housing (outer flexible metal casing) must be inspected for looseness between its convolutions. Looseness indicates either damage or a loss of interference fit between the outer housing and teflon liner, which maintains the housing length. Changes in housing length will affect the pulling stroke of the AR2 and could result in incomplete extraction of ripcord pins, which may result in death of parachutist.

WARNING

Make sure the jump and off decals are replaced on the correct sides of the switch lever. Incorrectly placed decals will give a false indication of AR2 condition and may result in death of parachutist if the AR2 is used in a jump.

WARNING

Be sure test chamber is disconnected from 110 VAC power before beginning disassembly to prevent injury to personnel.

THIS PAGE INTENTIONALLY LEFT BLANK

INSERT LATEST CHANGED PAGES / WORK PACKAGES. DESTROY SUPERSEDED DATA.

LIST OF EFFECTIVE / WORK PACKAGES

NOTE: The portion of text affected by the changes is indicated by a vertical line in the outer margins of the page. Changes to illustrations are indicated by miniature pointing hands. Changes to wiring diagrams are indicated by shaded areas.

Dates of issue for original and changed pages / work packages are:

Original ..0..21 Jun 00

**TOTAL NUMBER OF PAGES FOR FRONT MATTER AND REAR MATTER IS 32
AND TOTAL NUMBER OF WORK PACKAGES IS 42 CONSISTING OF THE
FOLLOWING:**

Page / WP* No.	Change No.	Page / WP* No.	Change No.	Page / WP* No.	Change No.
Title.....	0				
A – B.....	0				
a – d.....	0				
i – iv	0				
WP 0001 thru 0042	0				
Index 1 – index 8	0				

* Zero in this column indicates an original page or work package.

THIS PAGE INTENTIONALLY LEFT BLANK

***TM 10-1670-305-23&P
AIR FORCE T.O. 14D2-11-1
NAVSEA SS400-AY-MMO-010
MARINE CORPS TM 1670-23&P**

**HEADQUARTERS, DEPARTMENTS OF
THE ARMY, NAVY, & AIRFORCE
WASHINGTON, D.C., 21 JUNE 2000**

TECHNICAL MANUAL

**UNIT AND DIRECT SUPPORT MAINTENANCE MANUAL
(INCLUDING REPAIR PARTS AND SPECIAL TOOLS LISTS)**

**AUTOMATIC RIPCORD RELEASE, AR2, MODEL 451
NSN 1670-01-369-7914
TEST CHAMBER ASSEMBLY, AR2, MODEL 452
NSN 1670-01-370-0752
ELECTRONIC TEST CHAMBER ASSEMBLY, AR2, MODEL 453
NSN 1670-01-468-9471**

REPORTING ERRORS AND RECOMMENDING IMPROVEMENTS

You can help improve this manual. If you find any mistakes or if you know of a way to improve the procedures, please let us know.

ARMY - Mail DA Form 2028 (Recommended Changes to Publications and Blank Forms), or DA Form 2028-2, located in the back of this manual, direct to: Commander, U.S. Army Soldier Biological and Chemical Command, ATTN: AMSSB-RIM-E (N), 15 Kansas Street, Natick, MA 01760. You may also send in your recommended changes via electronic mail directly to <AMSSB-RIM-E@natick.army.mil>. A reply will be furnished directly to you. Instructions for sending an electronic 2028 may be found at the back of this manual immediately preceding the hard copy 2028.

AIR FORCE – Reports by U.S. Air Force units should be submitted on AFTO Form 22, Technical Order Publication Improvement Report, and forwarded to the address prescribed above for the Army. An informational copy of the prepared AFTO Form 22 shall be furnished to SA-ALC/LDEAM, Kelly AFB, TX 78241-6421.

NAVY – Submit NAVSEA Form 4160/1 (REV 2-99) to Commander, NSDSA Code 5E30, NAVSURFCENDIV, 4363 Missile Way, Port Hueneme CA 93043-4307. A reply will be sent to you.

MARINE CORPS – Submit NAVMC Form 10772 to Commander, Life Cycle Management Center (Code 826), 814 Radford Blvd., Albany, GA 31704-0320. A reply will be sent to you.

DISTRIBUTION STATEMENT A: Approved for public release; distribution is unlimited.

*This manual supersedes TM 10-1670-305-13&P, dated 30 June 1995

THIS PAGE INTENTIONALLY LEFT BLANK

TABLE OF CONTENTS

WP Sequence No.

WARNING SUMMARY

CHAPTER 1 – INTRODUCTORY INFORMATION WITH THEORY OF OPERATION

General Information.....	0001 00
Automatic Ripcord Release, Model 451, Equipment Description and Data	0002 00
Test Chamber Assembly, Equipment Description and Data	0003 00
Automatic Ripcord Release, Model 451, Theory of Operation.....	0004 00
Test Chamber Assembly, Theory of Operation.....	0005 00
Supporting Data for Repair Parts, Special Tools, TMDE, and Support Equipment.....	0006 00

CHAPTER 2 – OPERATING INSTRUCTIONS

Description and Use of Controls and Indicators.....	0007 00
Automatic Ripcord Release, Model 451, Operation Under Usual Conditions.....	0008 00
Test Chamber Assembly, Model 452, Operation Under Usual Conditions.....	0009 00
Electronic Test Chamber Assembly, Model 453, Operation Under Usual Conditions.....	0010 00
Test Chamber Assembly, Model 452, Operation Under Unusual Conditions.....	0011 00
Electronic Test Chamber Assembly, Model 453, Operation Under Unusual Conditions.....	0012 00

CHAPTER 3 – TROUBLESHOOTING PROCEDURES

Troubleshooting Procedures, General Information.....	0013 00
Troubleshooting Procedures	0014 00
Troubleshooting Procedures	0015 00

CHAPTER 4 – UNIT MAINTENANCE INSTRUCTIONS

Service Upon Receipt.....	0016 00
Preliminary Checks and Adjustments.....	0017 00
Preventive Maintenance Checks and Service (PMCS).....	0018 00
Power Cable Assembly, Main/Reserve, Unit Maintenance	0019 00
Automatic Ripcord Release, AR2, Jump/Off Switch Maintenance.....	0020 00
Test Chamber Assembly, Model 452, Unit Maintenance	0021 00
Electronic Test Chamber Assembly, Model 453, Unit Maintenance.....	0022 00
Preparation for Storage or Shipment	0023 00

CHAPTER 5 – DIRECT SUPPORT MAINTENANCE INSTRUCTIONS

Test Chamber Assembly, Model 452, Direct Support Maintenance.....	0024 00
Electronic Test Chamber Assembly, Model 453, Direct Support Maintenance	0025 00

CHAPTER 6 – SUPPORTING INFORMATION

References	0026 00
Maintenance Allocation Chart (MAC).....	0027 00
Maintenance Allocation Chart (MAC).....	0028 00
Repair Parts List and Special Tool List (RPSTL).....	0029 00
Automatic Ripcord Release, Model 451, Repair Parts List.....	0030 00
Test Chamber Assembly, Model 452, Repair Parts List.....	0031 00
Electronic Test Chamber Assembly, Model 453, Repair Parts List.....	0032 00

National Stock Number Index.....	0033 00
Part Number Index.....	0034 00
Components of End Items (COEI) and Basic Issue Items (BII) Introduction.....	0035 00
Automatic Ripcord Release, Model 451, Components of End Items (COEI) and Basic Issue Items (BII)	0036 00
Test Chamber Assembly, Model 452, Components of End Items (COEI) and Basic Issue Items (BII)	0037 00
Electronic Test Chamber Assembly, Model 453, Components of End Items (COEI) and Basic Issue Items (BII)	0038 00
Additional Authorization List (AAL) Introduction.....	0039 00
Expendable and Durable Items List Introduction.....	0040 00
Tool Identification List.....	0041 00
AR2 Maintenance Log.....	0042 00
Index	Index 1

HOW TO USE THIS MANUAL

In this manual, primary chapters appear in upper case/capital letters; work packages are presented in numeric sequence, e.g., 0001 00; paragraphs within work packages are not numbered and are presented in a titles format. For a first level paragraph title all upper case/capital letter, e.g., INTRODUCTION, the next subordinate paragraph title will have the first letter of the first word and of each principle word all upper case/capital letters, e.g., How to Use This Manual. The location of additional material that must be referenced is clearly marked. Figures supporting maintenance procedures/text are located as close as possible to their references.

FRONT MATTER. Front matter consists of front cover, warning summary, title block, table of contents, and how to use this manual page.

CHAPTER 1 – INTRODUCTION. Chapter 1 contains general information, equipment description, and theory of operation.

CHAPTER 2 – OPERATING PROCEDURES. Chapter 2 contains a description and use of controls and indicators, operating procedures under usual conditions and operating procedures under unusual conditions.

CHAPTER 3 - TROUBLESHOOTING PROCEDURES. Chapter 3 contains troubleshooting procedures authorized at unit level.

CHAPTER 4 – UNIT MAINTENANCE INSTRUCTIONS. Chapter 4 provides procedures for service upon receipt, preliminary checks and adjustments, preventive maintenance checks and services (PMCS), maintenance procedures authorized at unit level, and preparation for storage or shipment.

CHAPTER 5 – DIRECT SUPPORT MAINTENANCE INSTRUCTIONS. Chapter 5 provides maintenance procedures authorized at direct support level.

CHAPTER 6 – SUPPORTING INFORMATION. Chapter 6 contains references, maintenance allocation chart (MAC), expendable and durable items list, tool identification list, illustrated list of manufactured items, torque limits, mandatory replacement parts list, and wiring diagrams.

REAR MATTER – Rear matter consists of alphabetical index, DA Form 2028, authentication page, and back cover

THIS PAGE INTENTIONALLY LEFT BLANK

CHAPTER 1

INTRODUCTORY INFORMATION

WITH

THEORY OF OPERATION

FOR

AUTOMATIC RIPCORD RELEASE, AR2, MODEL 451

TEST CHAMBER ASSEMBLY, AR2, MODEL 452

ELECTRONIC TEST CHAMBER ASSEMBLY, AR2, MODEL 453

THIS PAGE INTENTIONALLY LEFT BLANK

GENERAL INFORMATION

0001 00

SCOPE

Type of Manual: Operators Unit and Direct Support Maintenance Manual (including Repair Parts and Special Tool List).

Model Numbers and Equipment names: Automatic Record Release, AR2, Model 451
Test Chamber Assembly, AR2, Model 452
Electronic Test Chamber Assembly, AR2, Model 453

Purpose of Equipment: The Automatic Ripcord Release, Model 451 (hereinafter referred to as AR2) automatically pulls the ripcord pins on a free falling parachute at a predetermined altitude. The Test Chamber Assembly, Model 452 and the Electronic Test Chamber Assembly, Model 453 are designed to test the AR2.

Maintainer Qualifications:

A maintainer must be certified by the USA QMC & S at Ft. Lee, VA in order to maintain the Automatic Ripcord Release, AR2, Model 451, Test Chamber Assembly, AR2, Model 452, and Electronic Test Chamber Assembly, AR2, Model 453.

MAINTENANCE FORMS, RECORDS, AND REPORTS

Reports of Maintenance and Unsatisfactory Equipment. Department of the Army forms and procedures used for equipment maintenance will be those prescribed in DA PAM 738-750. The Army Maintenance Management System (TAMMS) and DA PAM 738-751, The Army Maintenance Management System-Aircraft (TAMMLS-A).

Reports of Packaging and Handling Deficiencies. Fill out and forward Report of Discrepancy (ROD) Standard Form 364 (SF 364) as prescribed in AR 735-11-2/DLAR 4140.55/SECNAVINST 4355.73A/AFR 400-54/MCO 4430.3J.

Discrepancy in Shipment Report (DSR). Fill out and forward Discrepancy in Shipment Report (DSR) Standard Form 361 (SF361) as prescribed in AR 55-38/NAVUSPINST 4610.33C/AFR 75-18, MCO P4610.19./DLAR 4500.15.

Marine Corps Users-Marine Corps Forms and maintenance procedures used for equipment maintenance and reporting discrepancy/deficiencies are contained in TM 4700-15/1. Marine Corps organizations will use their local SOP and TM 4700-15/1 in performance of maintenance, record keeping, and reports on this equipment.

For Quality Deficiency Reports (QDR), Marine Corps users shall submit a Standard Form 368 (SF 368) in accordance with MCO 4855.10 to Life Cycle Management Center, ATTN: Product Support Section 822, 814 Radford Blvd., Albany, GA 31704-0320. A reply will be sent to you.

REPORTING EQUIPMENT IMPROVEMENT RECOMMENDATIONS (EIR)

You can help improve this manual. If you find a mistake or if you know of a way to improve the procedures, let us know.

ARMY - Mail DA Form 2028 (Recommended Changes to Publications and Blank Forms), or DA Form 2028-2 located in the back of this manual directly to: Commander, U.S. Army Soldier

REPORTING EQUIPMENT IMPROVEMENT RECOMMENDATIONS (EIR) – Cont

Biological and Chemical Command, ATTN: AMSSB-RIM-E(N), 15 Kansas Street, Natick, MA 01760. A reply will be furnished directly to you.

AIR FORCE - Reports by US Air Force units should be submitted on AFTO Form 22, Technical Order Publication Improvement Report, and forwarded to the address prescribed above for the Army. An information copy of the prepared AFTO Form 22 shall be furnished to ALC/LDEAM, Kelly AFB, TX 78241

NAVY - Submit NAVSEA Form 4160/1 (REV 2-99) to Commander, NSDSA Code 5E30, NAVSURFCENDIV, 4363 Missile Way, Port Hueneme CA 93043-4307. A reply will be sent to you.

MARINE CORPS - Submit NAVMC Form 10772 to Life Cycle Management Center, ATTN: Product Support Section 822, 814 Radford Blvd., Albany, GA 31704-0320. A reply will be sent to you.

CORROSION PREVENTION AND CONTROL (CPC)

Not Applicable

DESTRUCTION OF ARMY MATERIAL TO PREVENT ENEMY USE

Destruction of Army material to prevent enemy use shall be in accordance with TM 750-244-2.

PREPARATION FOR STORAGE OR SHIPMENT

Requirements for packaging and administrative storage are contained in Chapter 2.

WARRANTY INFORMATION

There is no warranty for the Automatic Ripcord Release AR2, Model 451, Test chamber Assembly, Model 452, or Electronic Test Chamber Assembly, Model 453.

NOMENCLATURE CROSS REFERENCE LIST

Common Name	Original Nomenclature
AR2	Automatic Ripcord Release

LIST OF ABBREVIATIONS

AGL	Above Ground Level
ALT	Altitude
AMP	Ampere
AR2	Automatic Ripcord Release
C	Celsius
CAGEC	Commercial and Government Entity Code
CHMBR	Chamber
COMP	Compressor
Cyl	Cylinder
D	Depth
DA	Department of the Army

LIST OF ABBREVIATIONS

ECP	Engineering Change Proposal
EMP	Electromagnetic Pulse
F	Fahrenheit
Fig	Figure
ft	Feet
FT MSL	Feet Mean Sea Level
Ft/sec	Feet per second
GFD	Ground
H	Height
HCI	Hardness Critical Item
Hz	Hertz
lbs	Pounds
LED	Light Emitting Diode
MAC	Maintenance Allocation Chart
MSL	Mean Sea Level
No.	Number
NSN	National Stock Number
P/N	Part Number
PMCS	Preventive Maintenance Checks and Services
PSI	Pounds per Square Inch
Pwr	Power
ROD	Report of Discrepancy
RPSTL	Repair Parts and Special Tools List
Sec	Second
SMR	Source Maintenance Recoverability
Sol	Solenoid
SRA	Specialized Repair Activity
Sup	Supply
TDR	Transportation Discrepancy Report
TM	Technical Manual
U/M	Unit of Measure
UOC	Usable On Code
VAC	Volts Alternating Current
Vac	Vacuum
W	Width
WP	Work Package

SAFETY, CARE AND HANDLING

Observe normal precautions to prevent any unit from being subjected to unusual jolts and dropping.

CALIBRATION

Calibration, testing and certification shall be performed at intervals specified in indicated work packages:

Automatic Ripcord Release, Model 451 – WP 0018 00.

Test Chamber Assembly, Model 452 – WP 0018 00.

Electronic Test Chamber Assembly, Model 453 – WP 0018

THIS PAGE INTENTIONALLY LEFT BLANK

**AUTOMATIC RIPCORD RELEASE, MODEL 451
EQUIPMENT DESCRIPTION AND DATA**

0002 00

**EQUIPMENT CHARACTERISTICS, CAPABILITIES AND FEATURES
CHARACTERISTICS**

Senses rate-of-fall and altitude above mean sea level (MSL) (not above ground level (AGL)).

Altitude dial is graduated to permit settings from 500 feet to 25,000 feet.

AR2 actuates when it falls through a preselected altitude at a fall rate of 80 ft/sec or greater.

CAPABILITIES AND FEATURES**WARNING**

If any AR2 is utilized for non-personnel purposes, such as cargo drops, it shall not be used subsequently for personnel jumps. Cargo may roll onto AR2 in landing and damage it sufficiently to cause it to malfunction in next use, which may result in death of parachutist.

Automatically removes ripcord pins on the parachute at a predetermined altitude.

Designed to remove ripcord pins on the reserve parachute but can be used with main parachute.

LOCATION AND DESCRIPTION OF MAJOR COMPONENTS

The AR2 basically consists of an aneroid with associated mechanism, rate-of-fall sensing chamber, and a spring-loaded power cable. All components except the power cable and its flexible conduit are contained in a housing. The housing provides all required chamber, passages and mounting pads for each component. An altitude setting dial and JUMP/OFF switch are mounted on the housing. The power cable ends in either a fixed or detachable eye which connects to the parachute ripcord pin. A lanyard assembly is attached to the power cable to protect the open end of the power housing when detached from the AR2.

LOCATION AND DESCRIPTION OF MAJOR COMPONENTS - CONT

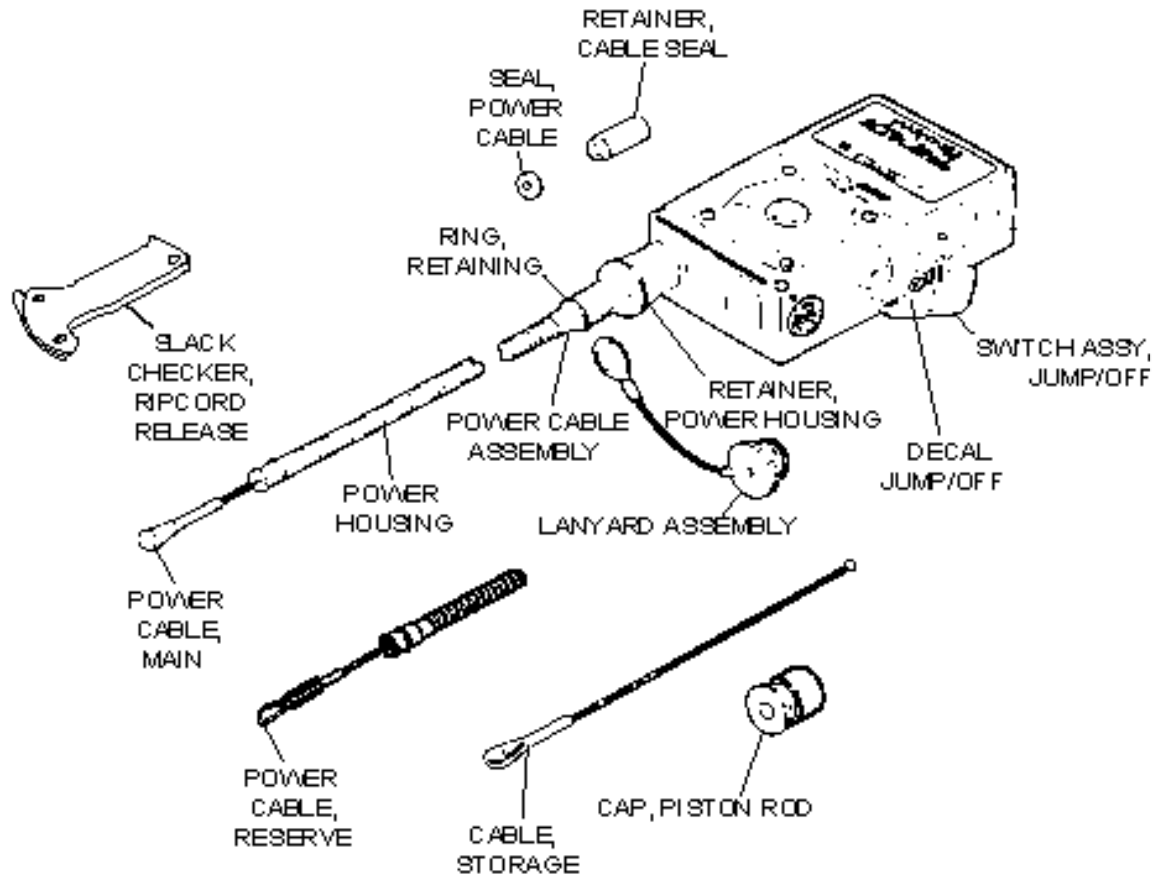

425-0037P

**AUTOMATIC RIPCORD RELEASE, MODEL 451
EQUIPMENT DESCRIPTION AND DATA**

0002 00

DIFFERENCES BETWEEN MODELS

Upgraded units are marked ECP-8 on service record decal.

EQUIPMENT DESCRIPTION	ALTITUDE DIAL INCREMENTS	LEAK CHECK INDICATOR	OVERTRAVEL SWITCH PIN
Original Issue	500 feet	6,000 feet	N/A
ECP-8 Upgrade	250 Feet	10,000 feet	X

EQUIPMENT DATA

Operational Data

Operating Range (altitude)	1,500 (feet) to 25,000 (feet) above MSL
Accuracy	± 300(feet) less than 10,000 feet above MSL ± 500 feet at 10,000 feet or more above MSL

NOTE

Cable measurements are from center of ball to farthest distance inside the eye hole.

Power Cable, Main	33.50 in. long
Power Cable, Reserve	26.19 in. long
Storage Cable	7.25 in. long

Environmental Conditions

Operational	
Altitude	1,000 (feet) to 35,000 (feet) above MSL
Temperature	-60°F (-51°C) to +122°F (+50°C)
Storage	
Altitude	-1,000 (feet) to 30,000 (feet) above MSL
Temperature	+41°F (+5°C) to +122°F (+50°C)

Physical Characteristics

Dimensions	1.6 in. H x 5.2 in. W x 3.1 in. D
Weight	1.9 lbs (without power cable)

THIS PAGE INTENTIONALLY LEFT BLANK

**TEST CHAMBER ASSEMBLY
EQUIPMENT DESCRIPTION AND DATA**

0003 00

EQUIPMENT CHARACTERISTICS AND FEATURES

CHARACTERISTICS (ALL MODELS)

Provides all equipment required to test the AR2.

CAPABILITIES AND FEATURES

Capable of testing the AR2 in the operating range of 1,500 (feet) to 25,000 (feet) above mean sea level (MSL).

CAUTION

Damage to internal components of the AR2 will occur if tested at rates of fall between 65 and 85 ft/sec.

MODEL 452

May be set to a rate of fall between 10 and 200 ft/sec.

MODEL 453

May be set to a rate of fall between 10 and 240 ft/sec except that rates between 65 and 85 ft/sec cannot be selected.

LOCATION AND DESCRIPTION OF MAJOR COMPONENTS (MODEL 452)

The test chamber basically consists of an air compressor, vacuum pump, altitude chamber with switch lever, lid and air cylinder, and a control assembly. All components are attached to a mounting base and are contained in a carrying case which also serves as the storage container.

The control assembly consists of a pressure (PSI) gage, ALTITUDE CONTROL (vacuum) regulator, CLIMB/FALL/COCK switch, RAPID FALL dump switch, PRESSURE CONTROL regulator, indicator light, ON/OFF switch, fuse, and an altimeter (ALT) on the control housing. Inside the control housing are a power supply for the altimeter vibrator, a dump solenoid valve, climb solenoid valve, air cylinder solenoid valve and all required plumbing and wiring.

TEST CHAMBER ASSEMBLY
EQUIPMENT DESCRIPTION AND DATA - Cont

0003 00

LOCATION AND DESCRIPTION OF MAJOR COMPONENTS (MODEL 452) - Cont.

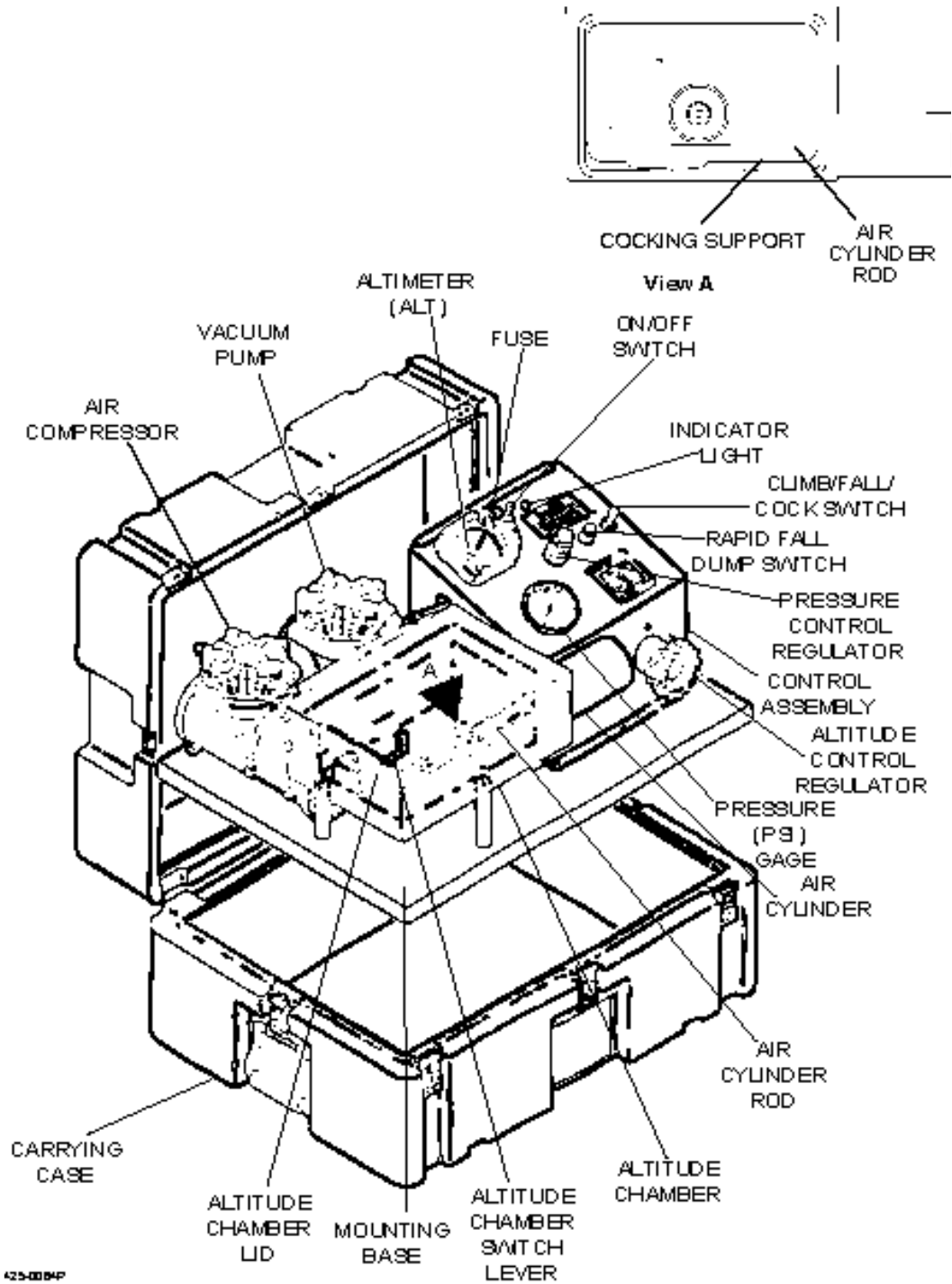

**TEST CHAMBER ASSEMBLY
EQUIPMENT DESCRIPTION AND DATA**

0003 00

LOCATION AND DESCRIPTION OF MAJOR COMPONENTS (MODEL 453)

The test chamber basically consists of a vacuum pump/air compressor assembly, altitude chamber and control assembly. All components are attached to a mounting base and are contained in a carrying case which also serves as a storage container.

The altitude chamber has a detector which senses the movement of the piston to the AR2. It is connected to the control assembly so that a Light Emitting Diode (LED) signals the instant the piston moves. It also has a provision for monitoring the position of the AR2 JUMP/OFF switch.

The control assembly is a self-contained, independently calibrated, completely interchangeable, removable unit. This unit contains a precision calibrated pressure sensor, a printed circuit board containing the required signal conditioning and operating logic, digital displays incorporating a preprogrammed microprocessor for pressure-to-altitude conversions, pneumatic valves and regulators to control altitude chamber conditions, regulated power supplies to run associated electronic circuits and devices, and operational controls and indicator lights to perform and monitor the various test functions. Finally, a quick-disconnect port is incorporated into the control assembly to provide access to a master altimeter for verifying calibration of the electronic pressure sensor.

TEST CHAMBER ASSEMBLY
EQUIPMENT DESCRIPTION AND DATA - Cont

0003 00

LOCATION AND DESCRIPTION OF MAJOR COMPONENTS (MODEL 453) - Cont

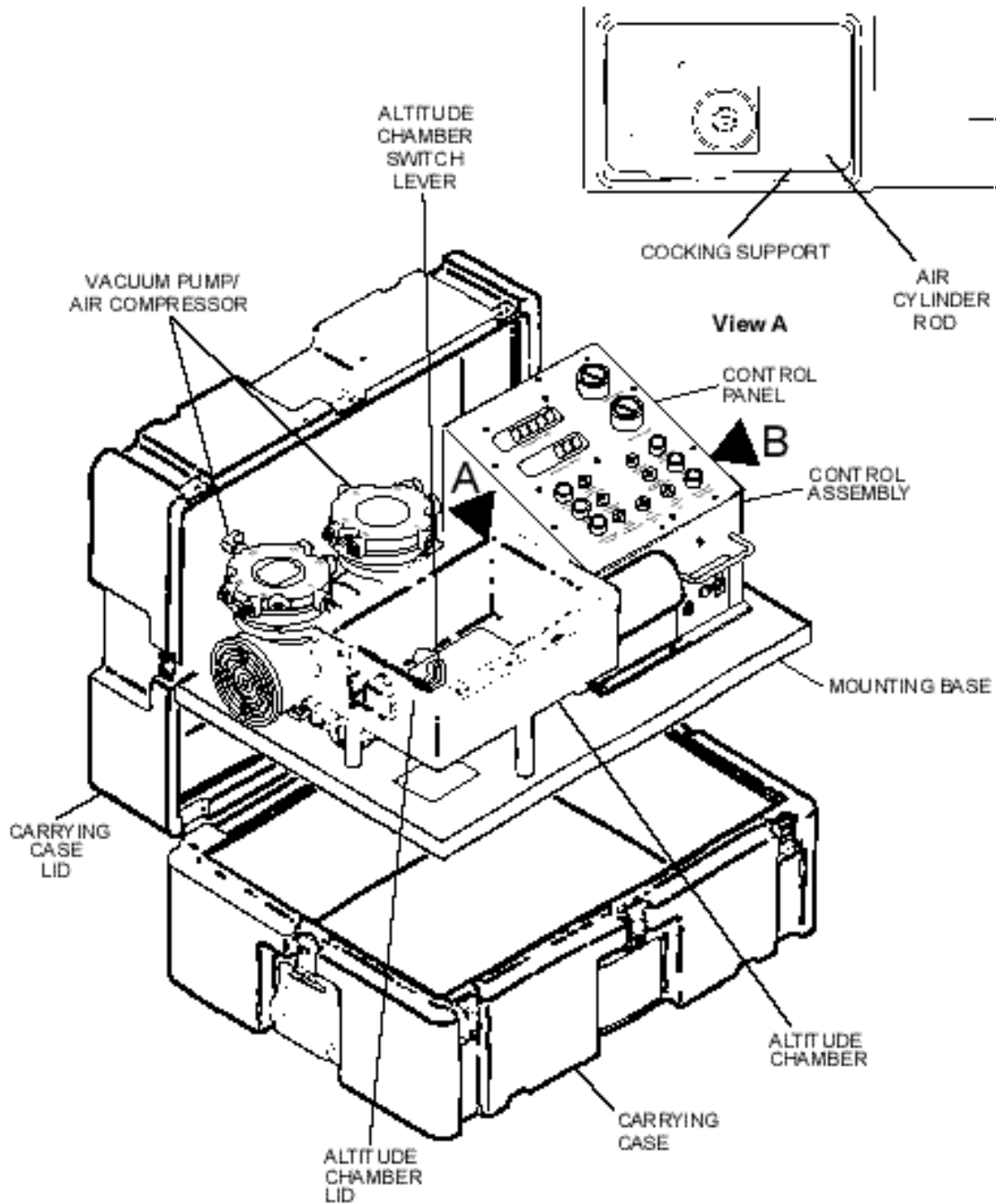

45-002P

TEST CHAMBER ASSEMBLY
EQUIPMENT DESCRIPTION AND DATA

0003 00

LOCATION AND DESCRIPTION OF MAJOR COMPONENTS (MODEL 453)

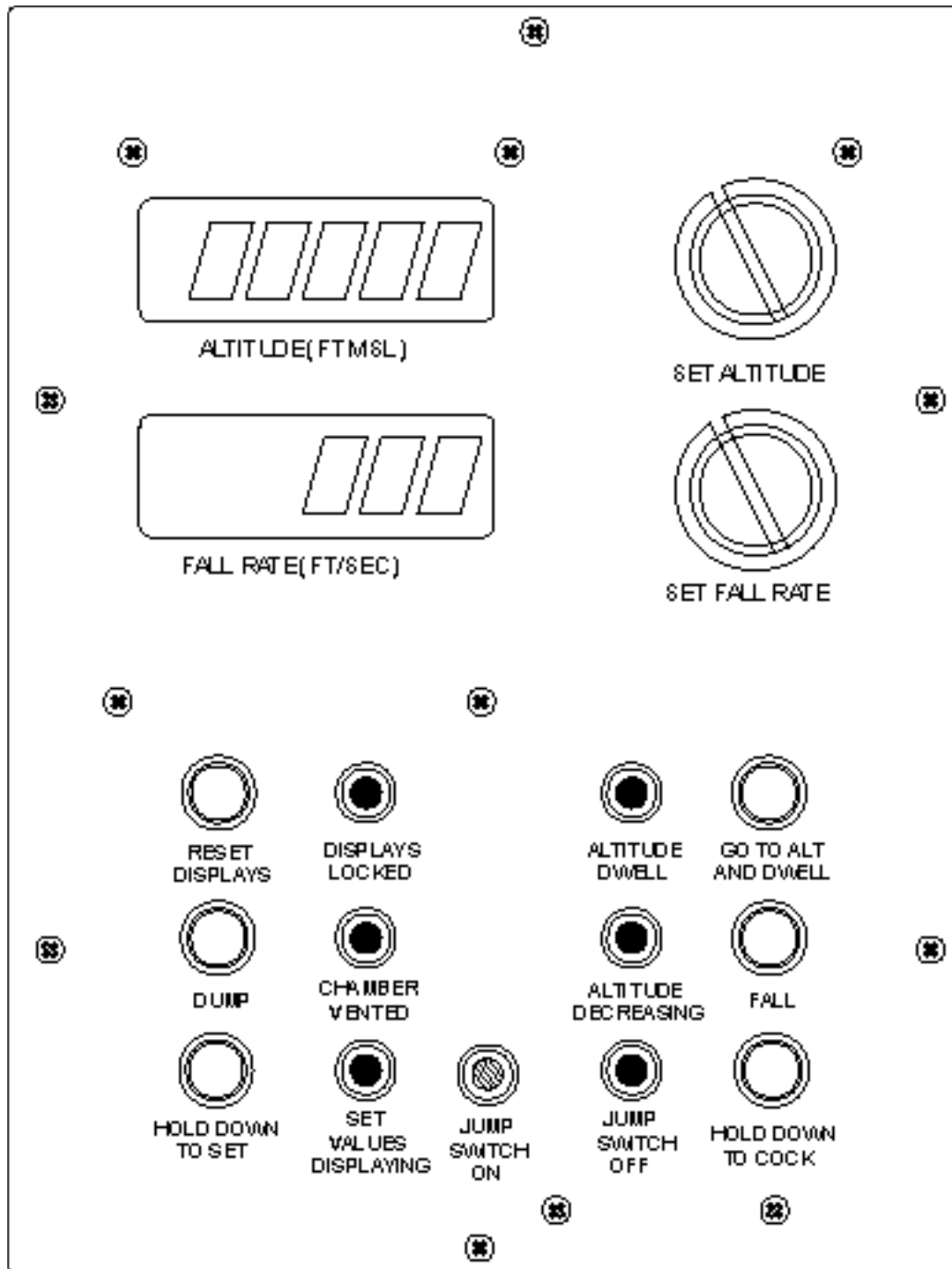

425-0000P

VIEW B

**TEST CHAMBER ASSEMBLY
EQUIPMENT DESCRIPTION AND DATA - Cont**

0003 00

EQUIPMENT CHARACTERISTICS, CAPABILITIES AND FEATURES

EQUIPMENT DATA (MODEL 452)

Operational Data

Operating Range (Altitude)	1,000 (feet) to 35,000 (feet) above MSL
Reading Resolution (Altitude)	50 (feet)

Power Requirements

110 VAC 60 Hz

Fuse Size

¼ DIA x 1-1/4 slow blow 5 AMP 250 volt

Environmental Conditions

Operational

Altitude	0 (feet) to 30,000 (feet) above MSL
Temperature	+41°F(+5°C) to +122°F (+50°C)

Storage

Altitude	-1,000 (feet) to 30,000 (feet) above MSL
Temperature	+41°F(+5°C) to +122°F (+50°C)

Physical Characteristics

Carrying Case

Dimensions	12.2 in. H X 25.9 in. W X 19.2 in. D
------------	--------------------------------------

Weight

Fully packed	70 lbs
Chamber w/o case	50 lbs

**ELECTRONIC TEST CHAMBER ASSEMBLY
EQUIPMENT DESCRIPTION AND DATA**

0003 00

EQUIPMENT CHARACTERISTICS, CAPABILITIES AND FEATURES

EQUIPMENT DATA (MODEL 453)

Operational Data

Operating Range (Altitude)	1,000 (feet) to 35,000 (feet) above MSL
Reading Resolution (Altitude)	1 (foot)
Operating Range (Rate-of-fall)	10 (ft/sec) to 240 (ft/sec)
Reading Resolution (Rate-of-fall)	0.1 (ft/sec)
Power Requirements	110 VAC 50/60 Hz
Fuse Size	¼ DIA x 1-1/4 slow blow 5 AMP 250 volt

Environmental Conditions

Operational

Altitude	0 (feet) to 35,000 (feet) above MSL
Temperature	+41°F(+5°C) to +122°F (+50°C)
Storage	
Altitude	-1,000 (feet) to 30,000 (feet) above MSL
Temperature	+41°F(+5°C) to +122°F (+50°C)

Physical Characteristics

Carrying Case

Dimensions	12.2 in. H X 25.9 in. W X 19.2 in. D
Weight	
Fully packed	60 lbs
Chamber w/o case	42 lbs

THIS PAGE INTENTIONALLY LEFT BLANK

**AUTOMATIC RIPCORD RELEASE, MODEL 451
THEORY OF OPERATION**

0004 00

The AR2 senses rate of fall and altitude above mean sea level (not above ground level). When the AR2 falls through the altitude set on the altitude dial at a rate of fall of over 80 ft/sec, the power cable will retract two inches (minimum) and at an initial force of 70 pounds. If the rate of fall is at a slower speed, such as 70 ft/sec, the AR2 will not actuate.

When the AR2 is used on the reserve parachute, the main parachute must be fully deployed at least 1,500 feet above the actuation altitude for the AR2. While in free fall, if the main parachute opens within only a few hundred feet above the actuation altitude, the fall rate mechanism may not have sufficient time to equalize pressure and deactivate. This could result in the deployment of two parachutes, leading to problems associated therewith. If the fall is initiated below the altitude set on the altitude dial, the AR2 will definitely actuate, and generally within 1,000 feet of free fall.

THIS PAGE INTENTIONALLY LEFT BLANK

THEORY OF OPERATION (MODEL 452)

The test chamber components are arranged according to the schematic diagram. The air compressor supplies compressed air at 40 PSI. It is used to cock the AR2 being tested and provides controlled air pressure to the altitude chamber. The rate at which air is introduced into the altitude chamber controls the simulated rate-of-fall of the AR2.

When in operation, if the air solenoid valve is opened by positioning the CLIMB/FALL/COCK switch to COCK, compressed air flows into the air cylinder and forces the piston to the right. This will cock the AR2. When the CLIMB/FALL/COCK switch is moved from the COCK position a vent in the solenoid valve allows the compressed air behind the piston to bleed off, thus enabling the AR2 to actuate under the appropriate conditions.

Compressed air is also available to the PRESSURE CONTROL regulator, which controls the rate at which air is introduced into the altitude chamber. Outlet pressure from the PRESSURE CONTROL regulator is registered on the pressure (PSI) gauge. Air thus regulated passes through a restrictor and on into the altitude chamber. By controlling the pressure, the simulated rate of fall of the AR2 may be varied.

The vacuum pump is connected to the altitude chamber through the ALTITUDE CONTROL regulator, which allows selection of any desired altitude up to 35,000 feet. When the CLIMB/FALL/COCK switch is moved to the CLIMB position, the climb solenoid valve opens. Turning the ALTITUDE CONTROL regulator knob allows selection of the desired altitude. Turning the knob counterclockwise will increase altitude. When the CLIMB/FALL/COCK switch is moved to the FALL position, the climb solenoid valve closes and the restrictor in the line from the PRESSURE CONTROL regulator allows controlled air pressure to enter the altitude chamber, causing the altitude to gradually decrease.

The RAPID FALL dump switch (push button) controls the dump solenoid valve. When the RAPID FALL dump switch is pressed the dump solenoid valve opens, and air from the compressor is introduced directly into the altitude chamber for rapid descent.

The ON/OFF switch controls power to both the air compressor and vacuum pump. When the air compressor and vacuum pump are running, the indicator light will illuminate. It will extinguish when the ON/OFF switch is positioned to OFF.

TEST CHAMBER ASSEMBLY
THEORY OF OPERATION - CONT

0005 00

THEORY OF OPERATION (MODEL 452) - CONT

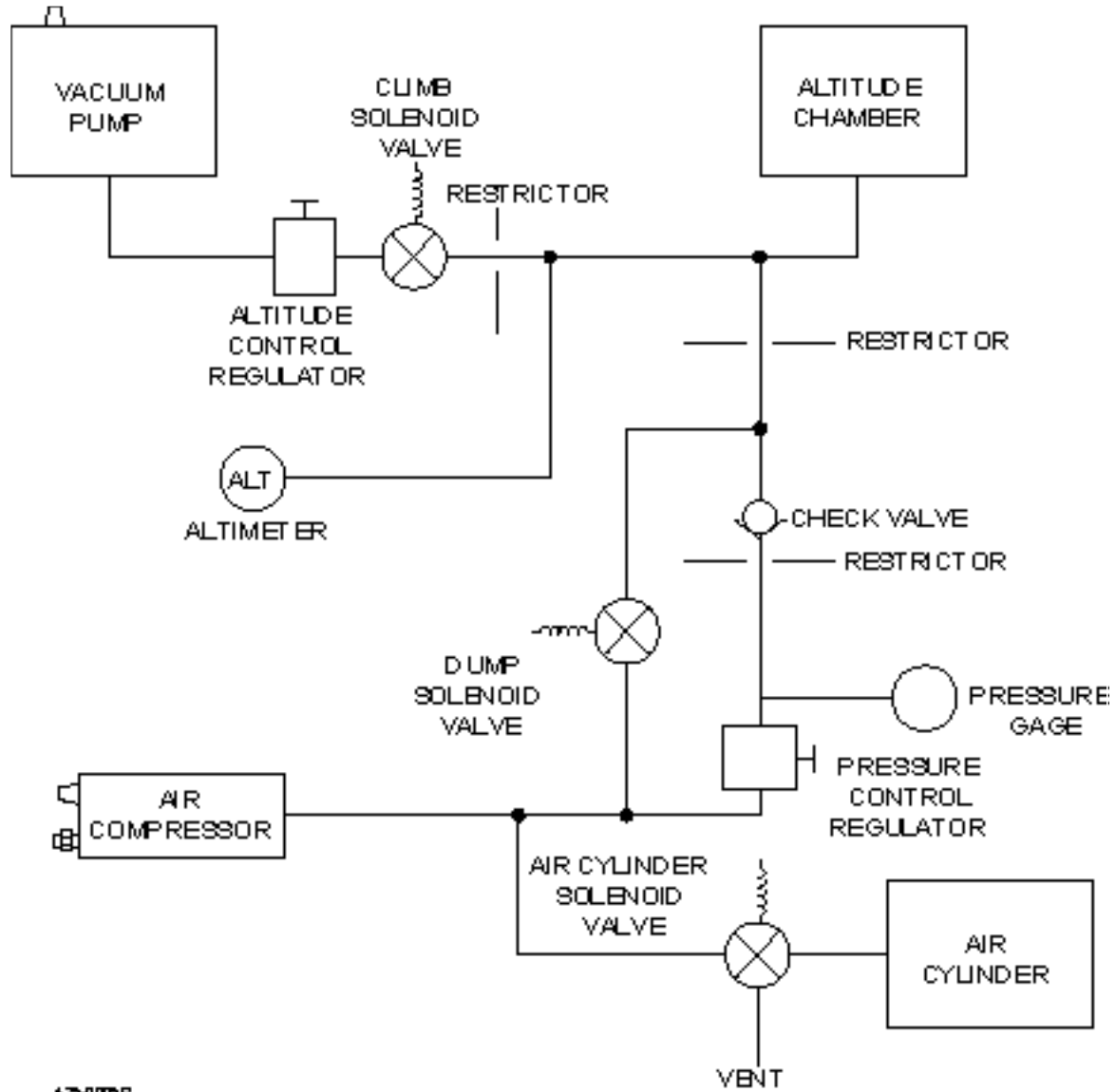

42-0005P

TEST CHAMBER ASSEMBLY
THEORY OF OPERATION

0005 00

THEORY OF OPERATION (MODEL 452)

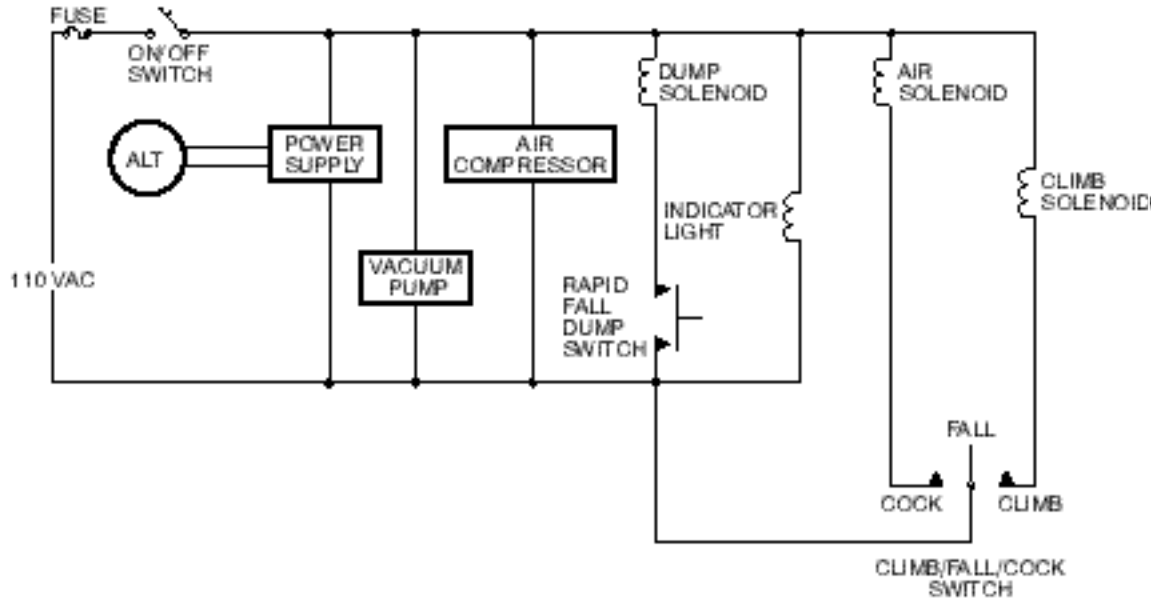

425-0054P

THEORY OF OPERATION (MODEL 453)

The AR2 is installed inside the transparent altitude chamber during testing. The JUMP/OFF switch and piston rod of the AR2 engage fittings inside the chamber which enable the switch to be operated and the AR2 to be recocked after actuation without opening the chamber lid or returning the unit to ground level. The ON and OFF position of the JUMP/OFF switch are electrically monitored by magnetic sensors in the bottom wall of the chamber. An infrared LED emitter/detector switch mounted inside the air cylinder senses movement of the piston rod assembly at the instant the AR2 actuates. Signals from these sensors are transmitted to the control assembly through an electrical connector in the left side wall of the control assembly near the front.

The combination vacuum pump/air compressor enables the operator to raise and lower the air pressure inside the sealed altitude chamber and thereby simulate the entire functional altitude range of the AR2. The compressor also provides regulated pressure to the air cylinder to cock the mechanism of the AR2. The necessary pneumatic plumbing connections between the pump/compressor unit, control assembly, and altitude chamber are located along the bottom left side wall of the control assembly. Power for the pump/compressor is supplied through a separate electrical connector, also located in the left side wall of the control housing. Routing and connections for all external electrical wiring and pneumatic plumbing are shown in schematics.

The control assembly is a self-contained, independently calibrated, completely interchangeable modular unit. It contains a precision calibrated pressure sensor, a printed circuit board incorporating signal conditioning and complete system operating logic, digital displays which feature a preprogrammed microprocessor for making pressure-to-altitude conversion, pneumatic valve and regulators to control altitude, regulated power supplies to run associated electronic circuits and devices, and operational controls and indicator lights to perform and monitor the various test functions. A quick disconnect port is located in the front wall of the control assembly to permit attachment of a precision pressure standard during periodic altimeter calibration. A separate auxiliary chamber used for calibrating wrist altimeters may also be connected through this port.

WP 0007 00 shows the configuration of the control panel. The altitude and fall rate displays are placed at the upper left with their respective setting controls at the right. The chamber can simulate altitudes greater than 35,000 feet MSL. The fall rate may be set to any value between approximately 10 and 240 feet per second, except that rates between 65 and 85 feet per second cannot be selected because actuation at these rates will cause increased wear to internal components of the AR2. The altitude display reads to the nearest foot, and the fall rate display reads to the nearest 0.1 foot per second with positive values indicating a descent and negative values indicating a climb. Although the displays are updated approximately two times per second, the internal circuitry of the altimeter is designed to instantaneously capture and hold the pressure sensor signal as soon as piston rod movement is detected by the infrared switch. The altitude corresponding to this pressure is then locked in and displayed as the actuation altitude at the next update interval.

Six (6) push button controls and seven (7) indicator lights are located on the control panel. In addition to their primary functions, several of the controls are provided with interlocking logic circuitry to preclude operations which are out of sequence or which might damage the AR2.

The description and function of the controls and lights are summarized in WP 0007 00.

TEST CHAMBER ASSEMBLY
THEORY OF OPERATION

0005 00

THEORY OF OPERATION (MODEL 453)

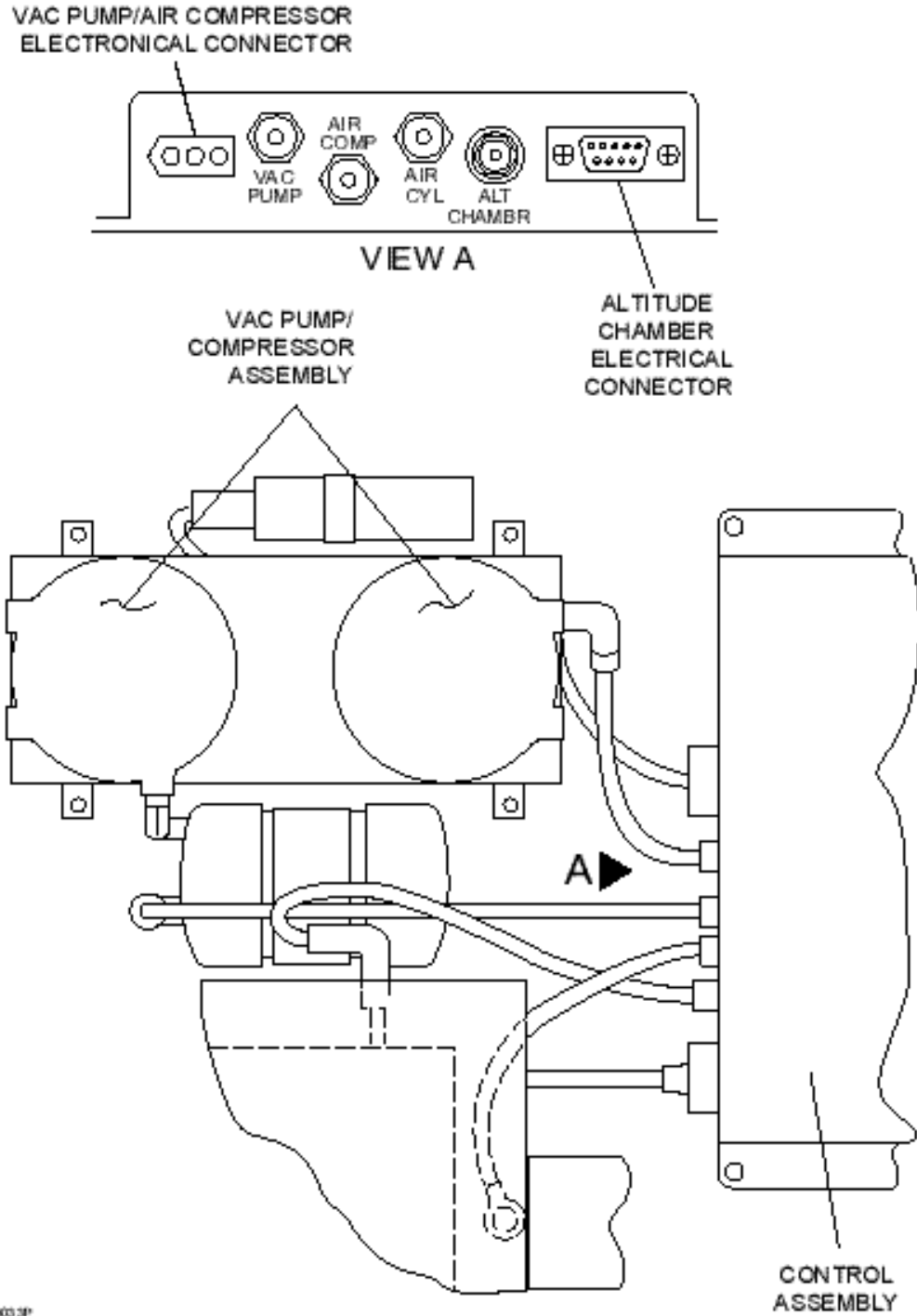

425-0003P

THIS PAGE INTENTIONALLY LEFT BLANK

**SUPPORTING DATA FOR REPAIR PARTS,
SPECIAL TOOLS, TMDE AND SUPPORT EQUIPMENT**

0006 00

REPAIR PARTS

Repair parts for the Automatic Ripcord Release, Model 451, Test Chamber Assembly, Model 452, and Electronic Test Chamber Assembly, Model 453, are listed and illustrated in WP 0030 00

SPECIAL TOOLS, TMDE AND SUPPORT EQUIPMENT

Special tools and support equipment for the Automatic Ripcord Release, Model 451, Test Chamber Assembly, Model 452, and Electronic Test Chamber Assembly, Model 453, are listed in WP 0028 00.

THIS PAGE INTENTIONALLY LEFT BLANK

CHAPTER 2

OPERATING INSTRUCTIONS

FOR

AUTOMATIC RIPCOR RELEASE, AR2, MODEL 451

TEST CHAMBER ASSEMBLY, AR2, MODEL 452

ELECTRONIC TEST CHAMBER ASSEMBLY, AR2, MODEL 453

THIS PAGE INTENTIONALLY LEFT BLANK

AUTOMATIC RIPCORD RELEASE, MODEL 451

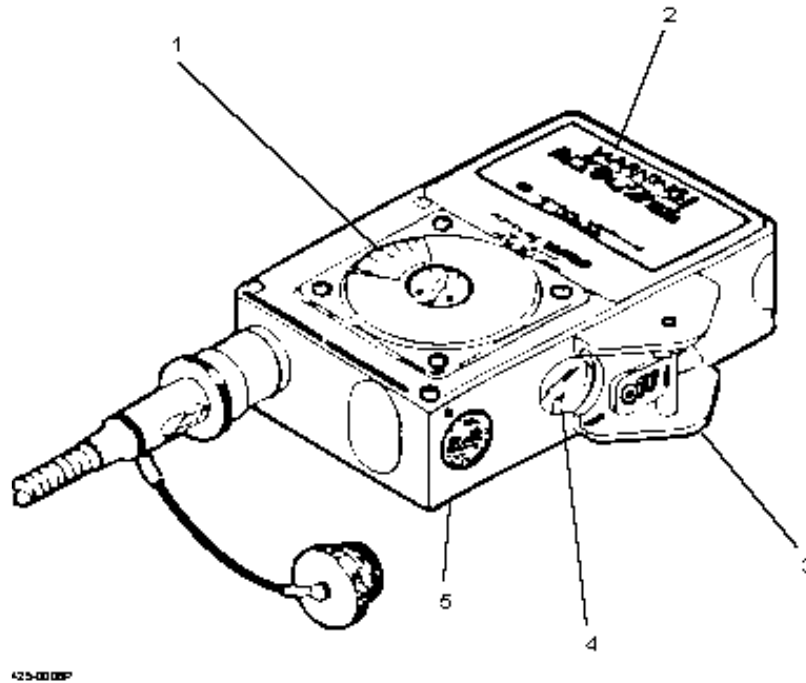

425-00 00P

KEY	CONTROL OR INDICATOR	FUNCTION OR USE
1	Altitude Dial	Allows preselection of altitude at which AR2 will actuate.
2	Warning Decal	Provides warning to operator
3	JUMP/OFF Switch	When set to JUMP, AR2 will become armed.
4	Aneroid Leak Indicator	Indicates local ground altitude when the Altitude Dial is set to at least 3,000 feet above the local altitude.
5	Service Record Decal	Indicates modification and overhaul on unit

TEST CHAMBER ASSEMBLY, MODEL 452

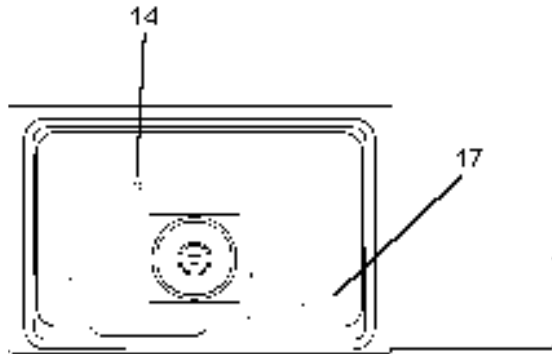

View A

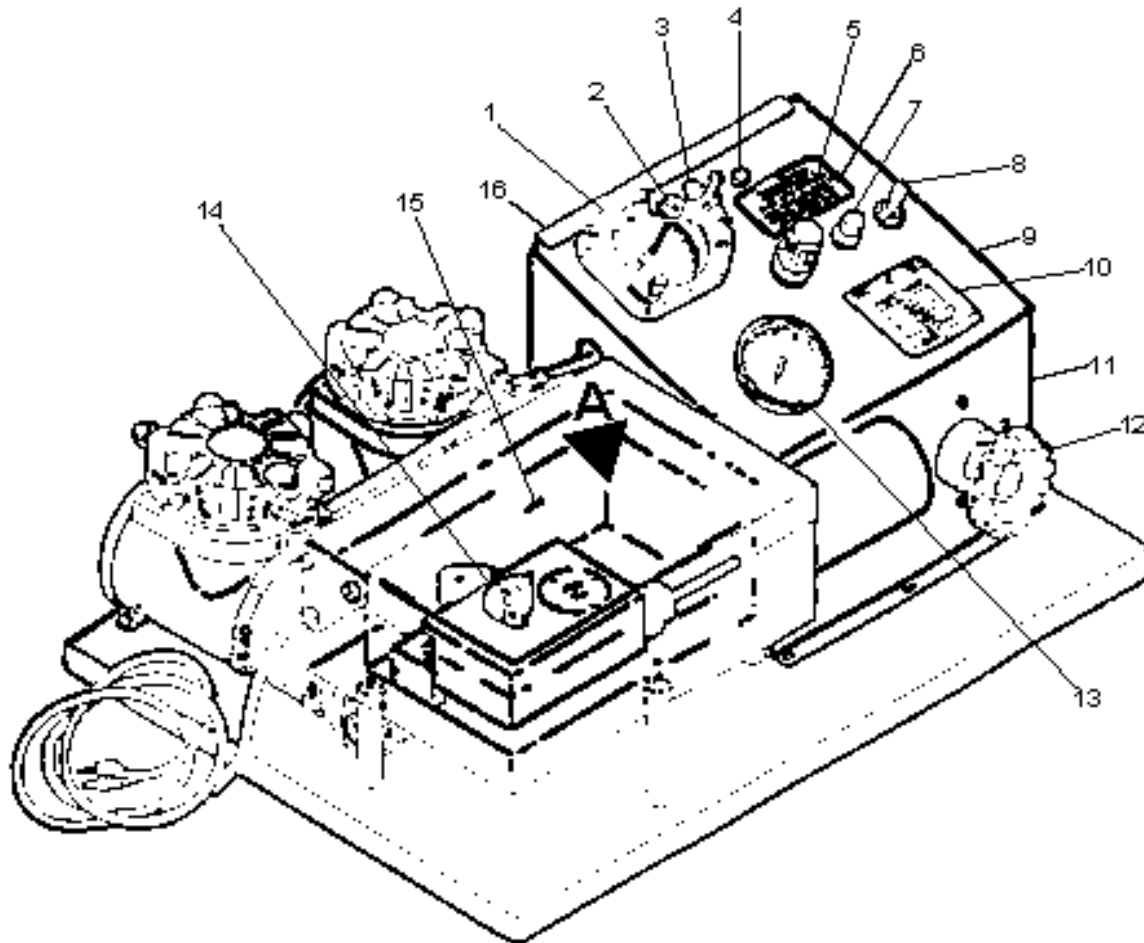

425-0045P

DESCRIPTION AND USE OF CONTROLS AND INDICATORS

0007 00

TEST CHAMBER ASSEMBLY, MODEL 452

KEY	CONTROL OR INDICATOR	FUNCTION OR USE
1	Altimeter	Indicates altitude inside chamber.
2	Fuse	Protects test chamber from electrical overload.
3	ON/OFF switch	Controls electrical power to the test chamber.
4	Indicator light	Lights when test chamber is powered up.
5	PRESSURE CONTROL regulator	Controls rate of fall.
6	WARNING decal	Operational warning.
7	RAPID FALL dump switch	Actuates altitude chamber dump solenoid to quickly reach sea level.
8	CLIMB/FALL/COCK switch	Actuates solenoids to change altitude chamber conditions. CLIMB: Opens climb solenoid so that chamber altitude setting can be made. FALL: Closes climb solenoid so that controlled air pressure enters the chamber, causing gradual decrease in altitude in chamber. COCK: Opens air solenoid to cock AR2 under test.
9	Identification decal	Identifies test chamber.
10	Functions decal	Provides information on rate of fall during testing.
11	Control assembly	Contains testing control components.
12	Altitude control regulator	Used to set altitude inside chamber.
13	Pressure gage (PSI)	Indicates relative rate of fall.
14	Altitude chamber switch lever	Operates AR2 JUMP/OFF switch when AR2 is enclosed in altitude chamber.
15	Altitude chamber lid	Allows access to altitude chamber.
16	Connections schematic decal	Provides identification of electrical connectors (mounted inside control assembly housing panel).
17	Cocking support	Aligns AR2 and altitude chamber piston rod.

ELECTRONIC TEST CHAMBER ASSEMBLY, MODEL 453

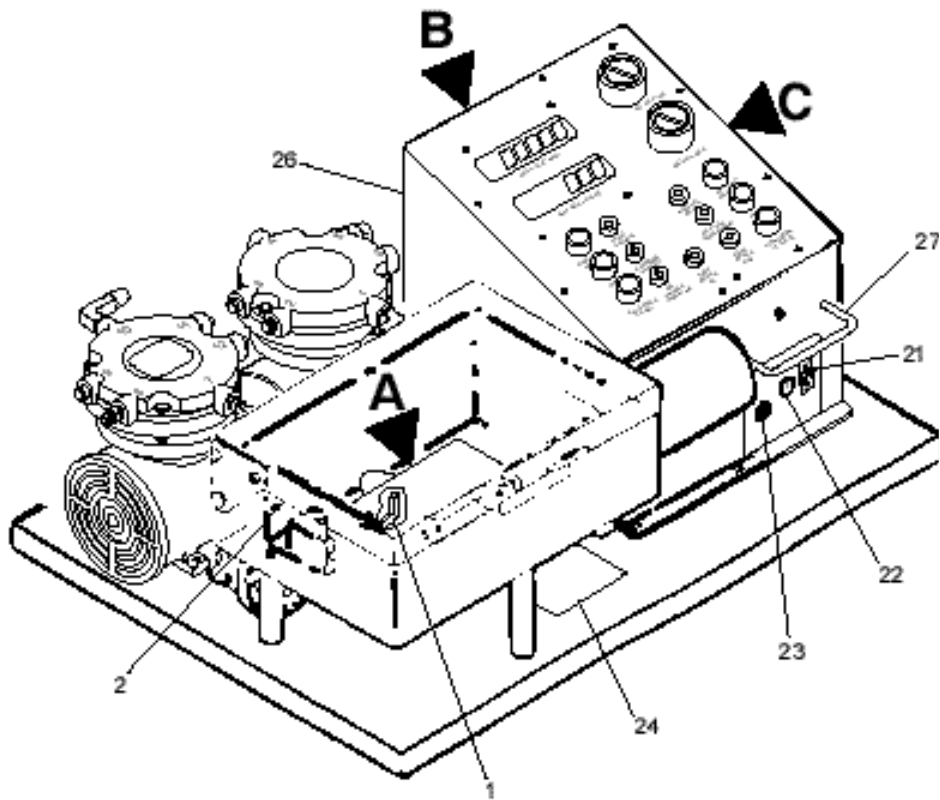
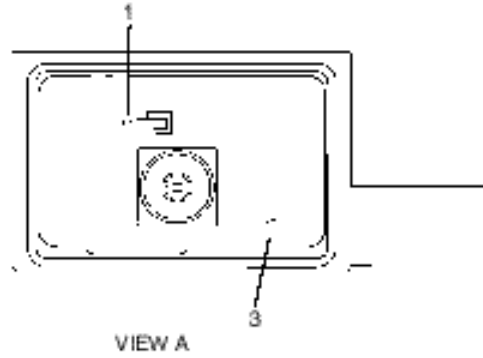
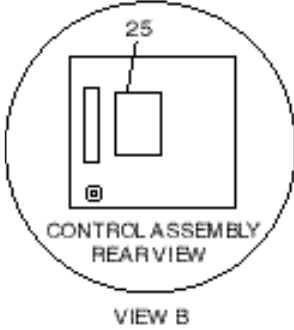

429-0047P

ELECTRONIC TEST CHAMBER ASSEMBLY, MODEL 453

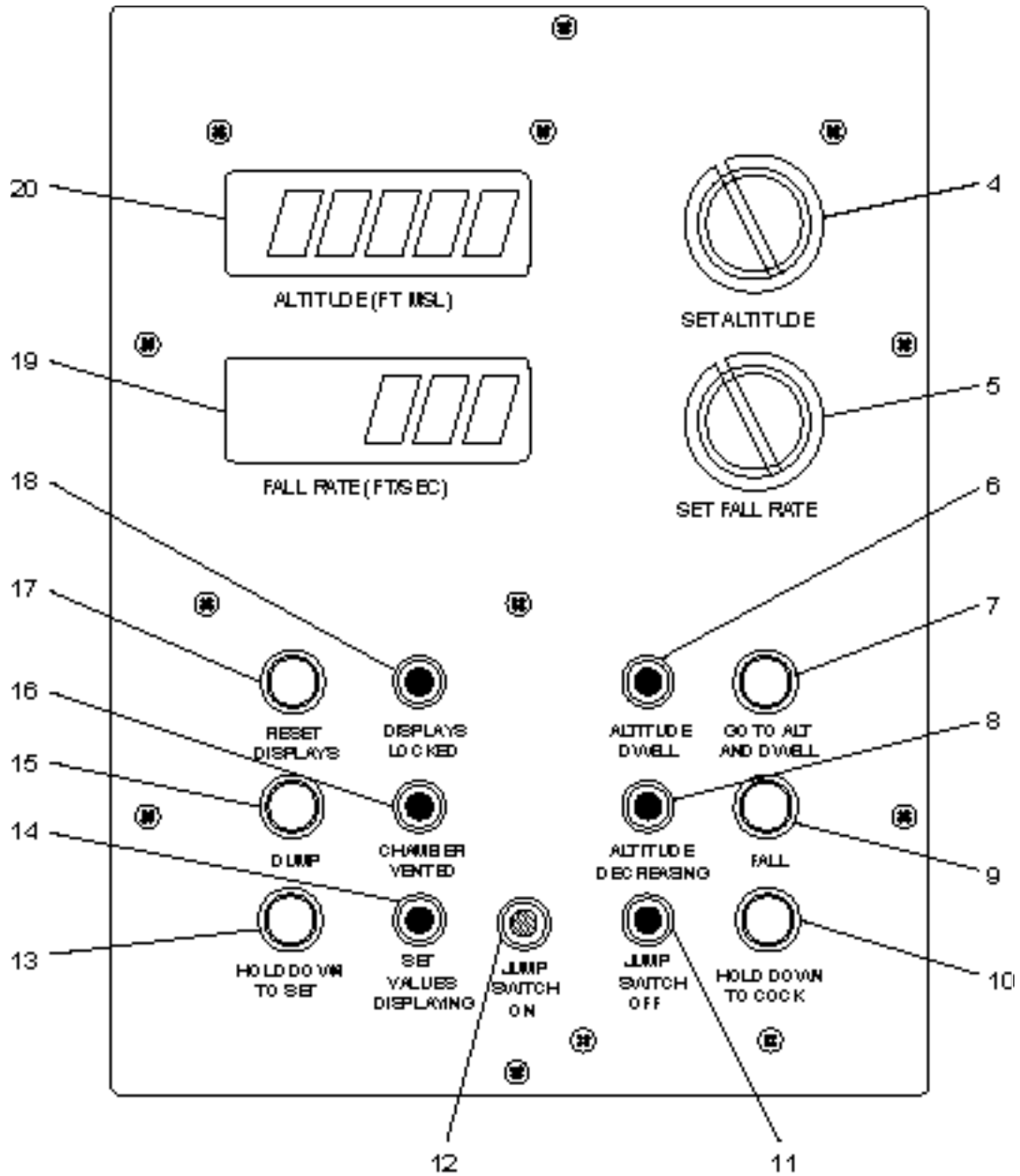

VIEW C

4-25-0000P

DESCRIPTION AND USE OF CONTROLS AND INDICATORS - CONT

0007 00

ELECTRONIC TEST CHAMBER ASSEMBLY, MODEL 453 – CONT

KEY	CONTROL OR INDICATOR	FUNCTION OR USE
1	Altitude Chamber Switch Lever	Operates AR2 automatic ripcord release JUMP/OFF switch when AR2 is enclosed in altitude chamber.
2	Altitude Chamber Lid	Allows access to altitude chamber.
3	Cocking Support	Aligns AR2 and altitude chamber piston rod.
4	SET ALTITUDE control	Use to set altitude in test chamber.
5	SET FALL RATE control	Use to set fall rate.
6	ALTITUDE DWELL indicator	Blinks continuously while the chamber is gaining altitude and during the time while the AR2 is stabilizing. When sufficient time at altitude has elapsed, the indicator will stop blinking and remain steadily illuminated, signifying that the test may be initiated. The indicator goes out when a valid FALL command is given.
7	GO TO ALT AND DWELL switch	Pressing this switch causes the chamber to climb to the set altitude. As this altitude is reached, the fall-rate value will decrease to zero. The switch will function with the chamber vented, but the chamber will not be able to gain altitude until the DUMP circuit is disengaged.
8	ALTITUDE DECREASING indicator	Becomes steadily illuminated when a valid FALL command is given. It remains illuminated while the test is in progress and after the AR2 actuates. It extinguishes when the GO TO ALTITUDE AND DWELL control is pressed.
9	FALL switch	Pressing this switch initiates the test. Because of interlocks built into the system, however, the switch will not function unless the AR2 has been recocked, the displays have been reset, sufficient dwell time at altitude has elapsed, the Jump switch has been set to ON and no other indicators are blinking or illuminated except the JUMP SWITCH ON indicator.
10	HOLD DOWN TO COCK switch	Depressing and holding this switch recocks the AR2 after an actuation. Its function may be verified by observing the movement of the piston rod through the lid of the altitude chamber. Interlocks in the system prevent this switch from functioning unless the AR2 is in the actuated condition and the JUMP/OFF switch is set to OFF.
11	JUMP SWITCH OFF indicator	This indicator remains steadily illuminated whenever the AR2 JUMP/OFF switch is in the fully OFF position.

DESCRIPTION AND USE OF CONTROLS AND INDICATORS

0007 00

KEY	CONTROL OR INDICATOR	FUNCTION OR USE
12	JUMP SWITCH ON indicator	This indicator remains steadily illuminated whenever the AR2 JUMP/OFF switch is in the fully JUMP position. Its color, green, matches that on the AR2 JUMP/OFF switch and signifies that the AR2 is prepared for the test. The FALL switch will not function unless this indicator is illuminated. Once the fall has been initiated, however, the JUMP/OFF switch may be returned to the OFF position without affecting the test. The AR2 will not actuate with the JUMP/OFF switch OFF.
13	HOLD DOWN TO SET switch	When this switch is depressed, the displays show the altitude and fall rate to which the chamber has been adjusted. As long as the button is held down, the values displayed on the meters are the set values. When the button is released, the meters display the presently existing chamber conditions. This switch will function at any time (even during a fall) except when the displays are locked.
14	SET VALUES DISPLAYING indicator	This indicator blinks continuously only while the HOLD DOWN TO SET switch is depressed.
15	DUMP switch	Pressing this switch vents the chamber to rapidly return to ambient altitude. This switch has a latching mechanism which keeps it locked in the on (CHAMBER VENTED) position until it is pressed again.
16	CHAMBER VENTED indicator	This indicator blinks continuously whenever the DUMP circuit is engaged.
17	RESET DISPLAYS switch	This switch clears the values locked into the displays from the previous actuation. To prevent inadvertent loss of data, the switch will not function until after the AR2 has been recocked.
18	DISPLAYS LOCKED indicator	This indicator becomes illuminated at the instant the AR2 actuates and blinks continuously while the displays are in the locked condition. It goes out when the RESET DISPLAYS switch is pressed, provided the correct conditions are present to reset the meters.
19	FALL RATE (FT/SEC) display	This indicator displays fall rate.
20	ALTITUDE (FT MSL) display	This indicator displays altitude.
21	ON/OFF switch	Use to turn unit ON and OFF.
22	Fuse, 5 AMP, slow blow	Protects circuitry in Control Assembly.
23	Calibration port	Use to connect calibration standard to control assembly.
24	Identification decal	Identifies Model 453 Electronic test chamber Assembly.
25	Control Assembly decal	Identifies control assembly and adjustment screws.
26	Control Assembly	Contains testing control components.
27	Lifting Handle	Use to lift test chamber.

THIS PAGE INTENTIONALLY LEFT BLANK

**AUTOMATIC RIPCORD RELEASE, MODEL 451
OPERATION UNDER USUAL CONDITIONS**

0008 00

SHELTER REQUIREMENTS

The AR2 should be stored and tested in a building that meets storage requirements outlined in TM 10-1670-201-23, T.O. 13C-1-41, or NAVAIR 13-1-17, at an altitude of 0 feet to 30,000 feet above MSL with temperature controlled between +41°F (+5°) to +122°F (+50°C).

ASSEMBLY AND PREPARATION FOR USE

The AR2 and power cables are shipped in separate multi-unit packages. Check for open, damaged, or dented package or evidence of dampness. Open packages. Remove and count AR2 and power cables. Compare count to shipping manifest.

Check for missing components, including damaged or missing decals.

CAUTION

Move the JUMP/OFF switch between the two detent positions only. Do not force the switch past either detent position. This may damage internal components of the AR2 and cause a malfunction.

Check that JUMP/OFF switch is secure and does not bind when operated. Check whether AR2 was packed with a storage cable and piston rod cap installed. Check that power cable has a lanyard assembly installed.

1. Remove AR2 storage cable (1) and piston rod cap (3). The AR2 is supplied with a short storage cable to permit relaxation of the power springs during long periods of non-use. The storage cable is fitted with an eye (2) of similar configuration to that of the power cable. The piston rod cap provides protection for the end of the piston rod on a cocked unit. The storage cable and piston rod cap must be removed prior to testing. Remove storage cable as follows:
 - a. Ensure that the AR2 JUMP/OFF switch is OFF.

NOTE

It requires approximately 70 pounds of pull to cock the AR2.

- b. Secure the AR2. Use a screwdriver or other suitable tool, inserted through eye (2) of storage cable to form a T-handle. Pull eye (2) of storage cable (1) until mechanism reaches the cocked position and storage cable remains extended.

**AUTOMATIC RIPCORD RELEASE, MODEL 451
OPERATION UNDER USUAL CONDITIONS - CONT**

0008 00

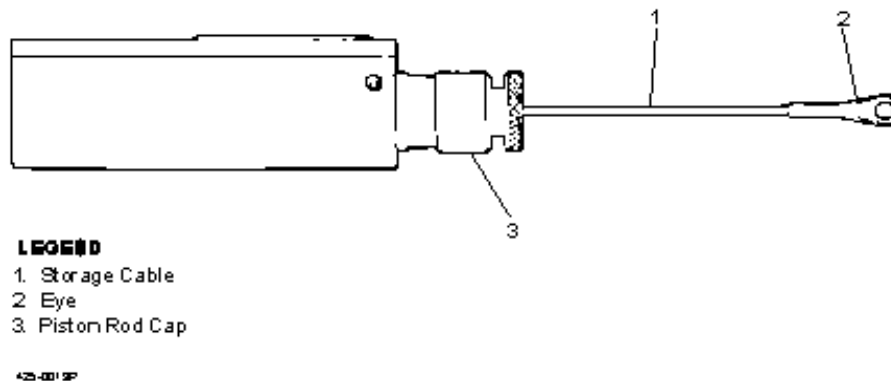
ASSEMBLY AND PREPARATION FOR USE - CONT

- c. Remove storage cable (1) and piston rod cap (3) by unscrewing piston rod cap and disengaging ball of storage cable from recess in piston rod.
- d. Visually inspect the storage cable for damage to the end fittings and for fraying of the cable or broken strands of wire. Remove from service any storage cable exhibiting damage.
- e. Do not discard serviceable storage cables. The storage cable should be used to relax the power springs of the AR2 if it will not be used within 120 days.
- f. Unless the AR2 is to be immediately placed in the test chamber, reattach the piston rod cap (3) to the unit to protect the end of the piston rod from external forces or impacts.

ASSEMBLY AND PREPARATION FOR USE

2. A Jump Log Record shall be maintained for each AR2 placed in service.
 - a. All parachute jumps with the AR2 must be recorded in an altered individual Army Parachute Log Record (DA Form 3912).
 - b. Alteration of the Army Parachute Log Record and subsequent entries will be accomplished as follows:
 - (1) On the front cover, after "ARMY PARACHUTE LOG RECORD", add "AR2".
 - (2) In the "JUMP, INSPECTION, AND REPACK DATA" page, make the following changes:
 - (a) In the heading, cross out "REPACK".
 - (b) Cross out the heading "BAG NUMBER" and enter "AR2 DIAL SETTING".
 - c. Record Information as follows:
 - (1) On the inside of the front cover, enter the individual AR2 serial number, type, date of manufacture, manufacturer, contract number, station, unit and date placed in service.
 - (2) On the "INSPECTION DATA" page, enter the date of the test, the altitude setting on the AR2 and the number of the jump.
 - d. Attach an individual Log Record to a serviceable AR2 as follows:
 - (1) Cut a 36-inch length of Ticket No. 5 cotton thread and double the thread length.
 - (2) Pass looped ends of doubled thread length around centerfold of Log Record and form a slip loop on outside at Log Record top.
 - (3) Pass thread length running ends through corner attaching hole from front cover of Log Record. Ensure running ends are routed over that part of the tread length located along the Log Record centerfold.
 - (4) Complete attachment tie by making a ½ inch on top of the slip loop previously made in step (2).
 - (5) Pass the loose ends of the cord length around power cable housing at a point adjacent to power housing retainer.
 - (6) Secure cord ends to cord length with three alternating half-hitches and an overhand knot in each tie end.

ASSEMBLY AND PREPARATION FOR USE - CONT

3. Maintenance Log Record shall be maintained for each AR2 placed in service.
 - a. Test results must be recorded on the local form (reproducible) contained in WP 0042 00. There is room on each form for three (3) test series. The interval between tests may be determined by the number of jumps (50) or by time since the last test (120 days), whichever comes first, or if there is a possibility that the AR2 was damaged or malfunctioned.
 - b. Record Information as follows:
 - (1) Record the AR2 serial number and date placed in service in the assigned spaces.
 - (2) Record the date of the test and the cumulative number of jumps in the assigned blocks. The cumulative number of jumps is determined by taking the number of jumps since the last test (obtained from the Jump Log Record) and adding this number to the previous cumulative number of jumps. Note that when the unit is first placed into service, the cumulative number of jumps will be zero.
 - (3) Enter the result of each test in the assigned space as the test is completed. If tests are repeated for any reason, such as an error in test procedure, record only the final result, but be sure to also record the total number of actuations.
 - (4) Enter the cumulative number of actuations in the assigned block. The cumulative number of actuations is determined by adding the number of actuations in the just completed test, together with any actuation noted in the Jump Log Record since the last test, to the previous cumulative number of actuations. Note that when the unit is first placed into service, the cumulative number of actuations will be the total number of actuations completed in the In-Service test.
 - (5) Note any unusual occurrences or conditions in the remarks space.
 - (6) Enter the date and signature of the tester in the assigned spaces.
4. Installation of the AR2.

Detailed instructions for installation of the AR2, AR2 pocket, and power cable assemblies are given in TM10-1670-287-23&P or service specific parachute packing manual.

OPERATING PROCEDURES

CAUTION

The power cable and power housing must be inspected if the AR2 was actuated prior to preparation for operation.

Perform pre-operational PMCS procedures before operating the AR2 (WP 0018 00).

Verify that the JUMP/OFF switch is in OFF position and that AR2 has been cocked at installation.

WARNING

If there is any indication of a leak in the aneroid, remove the AR2 from service. A leaking aneroid may cause a malfunction, which may result in death of parachutist.

Check the AR2s for aneroid leakage at ground level before every jump. The yellow indicator should indicate the local ground altitude when the altitude dial is set to an altitude at least 3,000 feet above the local altitude. Example: If local ground elevation is 500 feet above mean sea level, and the altitude dial is set at 3,500 feet or above, the yellow indicator should be approximately half way between the mean sea level mark and the 1,000-foot mark. If there is a leak in the aneroid, the yellow indicator will show some altitude above 500 feet, such as 2,000 or 3,000 feet or higher.

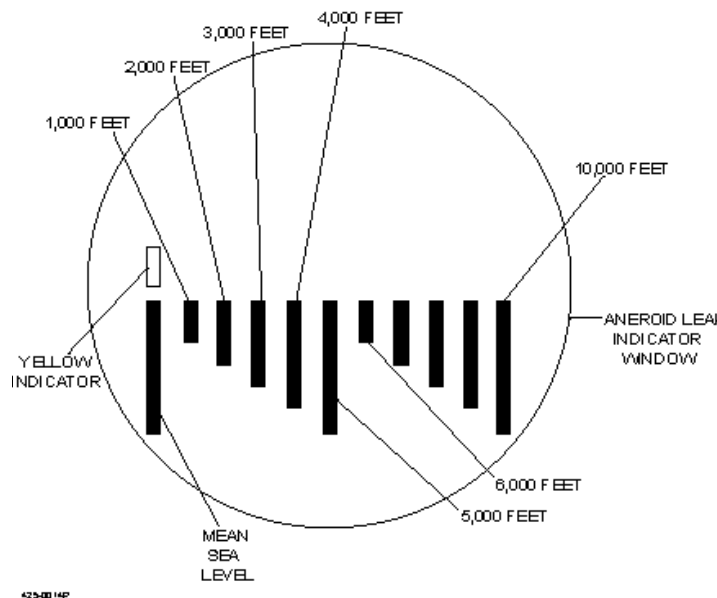

Note: Original issue AR2s have graduations between sea level and 6,000 feet only.

Aneroid Leak Indicator (ECP-8 Upgrade Version)

OPERATING PROCEDURES - CONT**WARNING**

The altitude dial indicates thousands of feet above mean sea level (not above ground level). If altitude dial is incorrectly set, two parachutes may deploy and become entangled, which may result in death of parachutist.

4. Before jumping, verify that altitude dial is set at desired setting.

WARNING

Do not move the JUMP/OFF switch to jump unless the equivalent pressure altitude inside the aircraft is at least 1,500 feet above the altitude set on the dial. It is imperative that the AR2 remains well above its actuation altitude at all times after the jump/off switch has been moved to jump. If there is a temporary reduction in aircraft altitude, and the AR2 switch is not recycled back to jump after again rising above the actuation altitude, the AR2 will actuate prematurely during the jump, possibly causing deployment of two parachutes which may become entangled, which may result in death of parachutist.

CAUTION

Move the JUMP/OFF switch between the two detent positions only. Do not force the switch past either detent position. This may damage the internal mechanism of the AR2 and cause a malfunction.

NOTE

If the dial setting must be changed in flight set the AR2 JUMP/OFF switch to OFF and reset the dial. Do not set the JUMP/OFF switch back to JUMP until the equivalent pressure altitude inside the aircraft is at least 1,500 feet above the new altitude dial setting.

5. Move JUMP/OFF switch to JUMP. Verify that switch is all the way over to detent position.

OPERATING PROCEDURES**WARNING**

When the AR2 is used on the reserve parachute, the main parachute must be activated at an altitude high enough to obtain a fully deployed canopy at least 1,500 feet above the actuation altitude for the AR2. If the main parachute opens within only a few hundred feet of the AR2 actuation altitude, the AR2 may deploy the reserve parachute. The two parachutes may become entangled, which may result in death of parachutist.

WARNING

The JUMP/OFF switch must be set to OFF immediately after every jump. Setting the JUMP/OFF switch to OFF repositions the mechanism for the next jump and prevents inadvertent actuation on the ground or during transport. If the switch is left in JUMP position, the next jump will cause the AR2 to actuate prematurely. Two parachutes may deploy and become entangled, which may result in death of parachutist.

6. After completing the jump, move the JUMP/OFF switch to OFF. Verify that switch is in the detent position.
7. With the JUMP/OFF switch in the OFF position, prepare the AR2 for the next jump by repeating steps 1 through 4.
8. After every jump and /or repack of the main chute the rigger is to inspect cable extension length with the slack checker as follows:

NOTE

When using the Reserve power cable assembly (with detachable eye), it will not be possible to employ the slack checker.

**AUTOMATIC RIPCORD RELEASE, MODEL 451
OPERATION UNDER USUAL CONDITIONS - CONT**

0008 00

OPERATING PROCEDURES - CONT

- a. The parachute system must have an AR2 and power cable assembly correctly installed and routed to the reserve parachute. Ensure that the position of the AR2 in the pocket is the same as when worn by a jumper.
- b. Open top flap of parachute to expose the reserve ripcord pins.
- c. Refer to Figure 1. Slide the metal head of the slack checker under the power cable from the right side so the cable slips into the curved groove between the metal head and plastic handle. Engage the two contact points on the hooked end of the slack checker with the mouth of the end fitting of the power cable housing. The slack checker should be held flat against the parachute pack. The two contact points must be engaged at all times to ensure proper inspection.
- d. Refer to Figure 2. Grasp the slack checker with the right hand, palm down, and with the thumb pressed into the curved recess. Grasp the swaged section of the ripcord pin with left hand. Simultaneously rotate the slack checker and ripcord pin in the directions shown by the arrows. Hold the ripcord pin with the left hand in a fixed position when it becomes horizontally aligned.
- e. Apply force as necessary to rotate the slack checker until all of the slack in the power cable has been taken up. Ensure that the pin does not slip out of the closing loop of the parachute. Note the position of the swaged end of the power cable eye with respect to the index surface on the slack checker:
 - (1) Refer to Figure 3. If the power cable assembly is correctly routed and installed, and has not been damaged, the end of the eye should not extend past the index surface.

WARNING

Any amount of extension past the index surface may mean the ripcord pins will not be pulled, which may result in death of parachutist.

- (2) Refer to Figure 4. If the end of the eye does extend past the index surface, then something is wrong with the cable routing, or the power housing (conduit) may be damaged. The power cable assembly should be removed from service immediately.
- f. The rigger shall record satisfactory completion of inspection with the slack checker in the main parachute log record book (DA Form 3912). The slack checker test will be annotated in the *JUMP, INSPECTION AND REPACK DATA* section, in the area marked *BAG NUMBER* as follows: "SC Test PASS/FAIL".

**AUTOMATIC RIPCORD RELEASE, MODEL 451
OPERATION UNDER USUAL CONDITIONS**

0008 00

OPERATING PROCEDURES

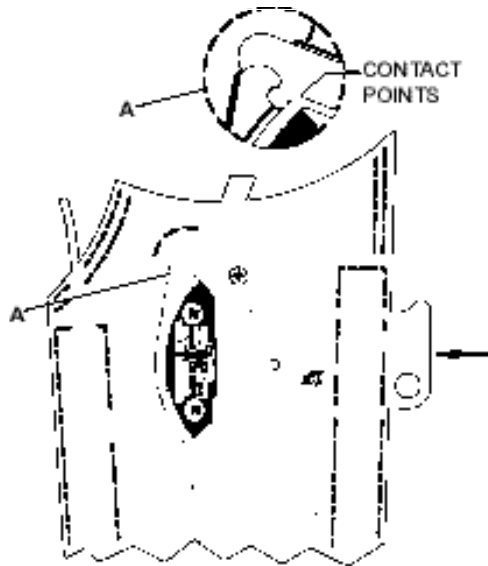

FIGURE 1.

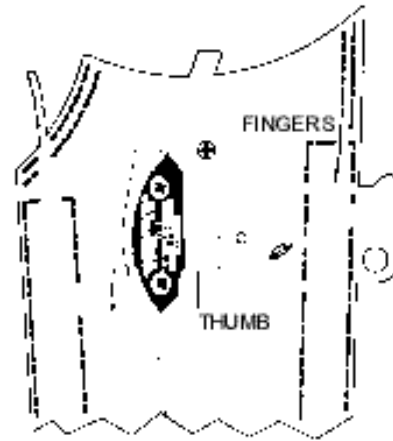

FIGURE 2.

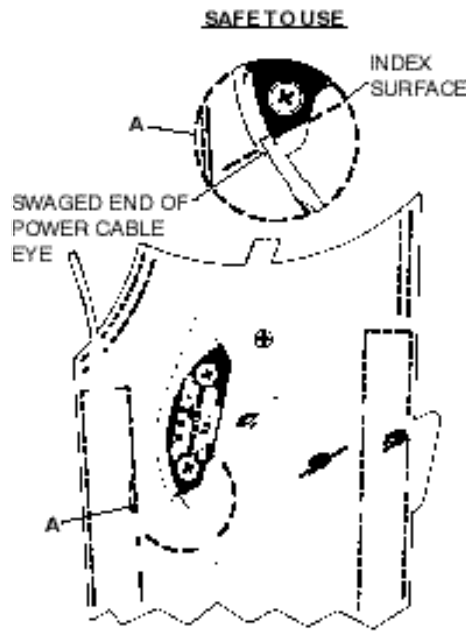

FIGURE 3.

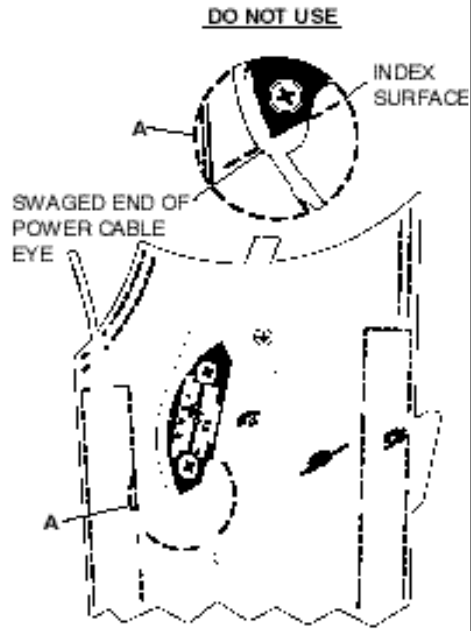

FIGURE 4.

425-0045P

**AUTOMATIC RIPCORD RELEASE, MODEL 451
OPERATION UNDER USUAL CONDITIONS - CONT**

0008 00

DECALS AND INSTRUCTION PLATE

SERVICE RECORD decal provides a place to record service record of the AR2. (For locations, refer to WP 0007 00).

WARNING

Operator warning decal provides warning to the operator (for location, refer to WP 0007 00).

PREPARATION FOR MOVEMENT

Whenever the AR2 is not attached to the power cable assembly or being tested, the piston rod cap shall be installed

**TEST CHAMBER ASSEMBLY, MODEL 452
OPERATION UNDER USUAL CONDITIONS**

0009 00

SITING REQUIREMENTS

The test chamber requires bench space approximately 36 inches wide by 30 inches deep with a 110 VAC, 60 Hz power source within six feet of the unit.

SHELTER REQUIREMENTS

The test chamber shall be contained in a building that meets storage requirements outlined in TM 10-1670-201-23, T.O. 13C-1-41, or NAVAIR 13-1-17, with an altitude between 0 (feet) to 30,000 (feet) above MSL. Temperature shall be between +41°F (+5°C) and +122°F (+50°C).

ASSEMBLY AND PREPARATION FOR USE

The test chamber assembly carrying case is designed for movement and storage and no external packaging is required.

WARNING

Test chamber and carrying case weighs 70 lbs. The mounting base with attached components weighs 50 lbs. Use two persons or lifting device when lifting to prevent injury to personnel.

Open test chamber assembly case cover. Lift and remove test chamber from carrying case (WP 0003 00). Place test chamber on work bench.

Check for loose or missing attaching hardware or decals. Assure that all adjustable knobs and switches are present and operate without binding. Check for broken glass on test chamber control assembly gages. Check for damage to altitude chamber gasket. Retain carrying case for future movement of unit. Report any discrepancies on SF 364 Report of Discrepancy (ROD).

INITIAL ADJUSTMENT BEFORE USE

CAUTION

Do not transport or store AR2 without piston rod cap or power cable attached. External forces or impacts applied to the piston rod may cause unit to malfunction. Any AR2 subjected to external forces or impact must be tested and, if necessary, removed from service.

Do not operate test chamber while in the carrying case. Components will overheat and may become damaged.

NOTE

To obtain correct rate-of-fall data, always install an AR2 in the altitude chamber before testing.

TEST CHAMBER ASSEMBLY, MODEL 452
 OPERATION UNDER USUAL CONDITIONS - CONT

0009 00

INITIAL ADJUSTMENT BEFORE USE - CONT

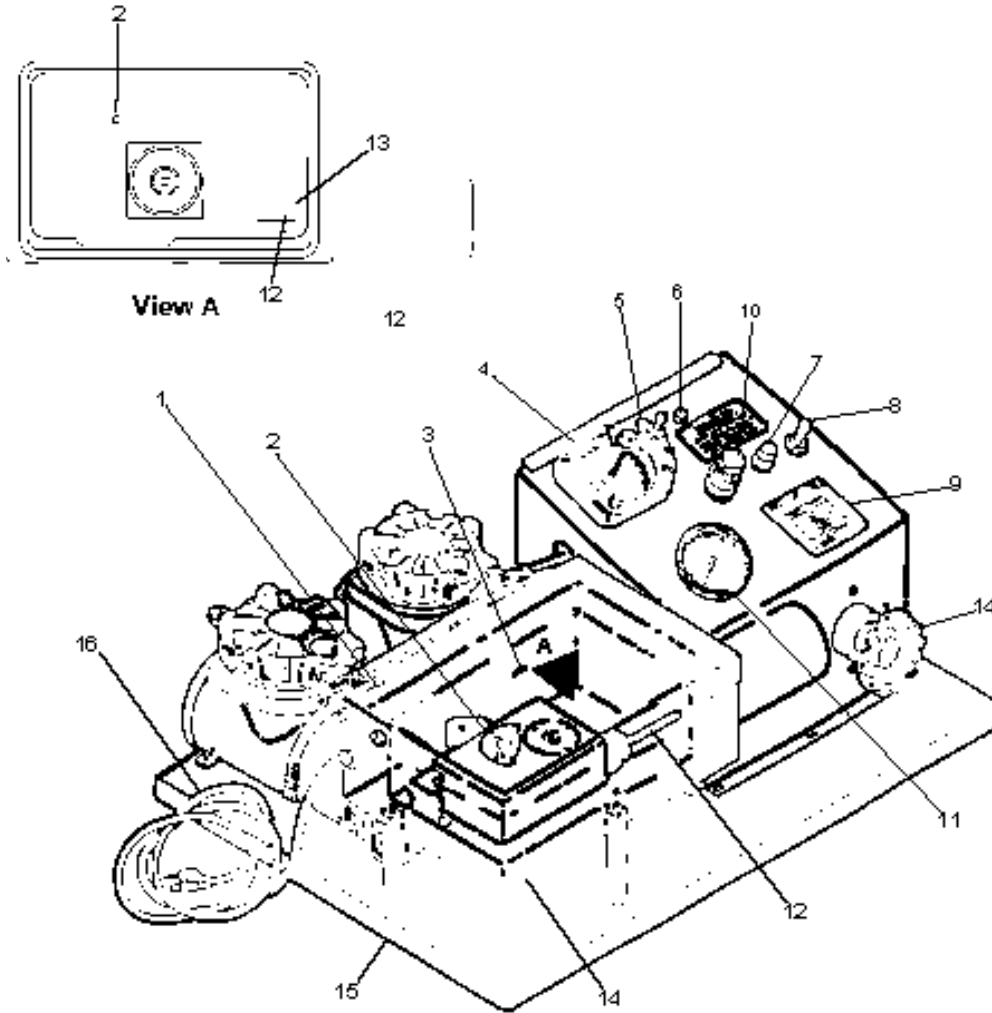

LEGEND

- | | |
|----------------------------------|--------------------------------|
| 1. ALTITUDE CHAMBER LID | 8. CLIMB/FALL/COCK SWITCH |
| 2. ALTITUDE CHAMBER SWITCH LEVER | 9. FUNCTIONS DECAL |
| 3. AR2 TEST UNIT | 10. PRESSURE CONTROL REGULATOR |
| 4. ALTIMETER | 11. PRESSURE GAGE |
| 5. ON/OFF SWITCH | 12. AIR CYLINDER ROD |
| 6. INDICATOR LIGHT | 13. COCKING SUPPORT |
| 7. RAPID FALL DUMP SWITCH | 14. ALTITUDE CONTROL REGULATOR |
| | 15. MOUNTING BASE |
| | 16. POWER CORD |

45-0045P

**TEST CHAMBER ASSEMBLY, MODEL 452
OPERATION UNDER USUAL CONDITIONS**

0009 00

INITIAL ADJUSTMENT BEFORE USE

NOTE

Ensure that the test chamber is in calibration (WP 0018 00).

1. Mount a AR2 test unit in the test chamber as follows:
 - a. Verify that the AR2 test unit (3) is in the cocked condition, and the AR2 JUMP/OFF switch is in the OFF position.
 - b. Remove the storage cable and piston rod cap from the AR2 (WP 0008 00).

WARNING

The heads of the air compressor and vacuum pump become hot with use and can cause burns to unprotected skin. Do not touch these components during operation or until they have been allowed to cool down after the test chamber has been switched off.

NOTE

The barometric pressure adjustment setting on the altimeter shall always remain at 29.92.

- c. Open altitude chamber lid (1).

NOTE

A specific dial setting for the AR2 is not required to conduct this test.

NOTE

It may be necessary to push the air cylinder rod (12) in or out to attach the piston rod of the test unit.

- d. Insert test unit into altitude chamber ensuring that the AR2 JUMP/OFF switch is aligned with the altitude chamber switch lever (2); use the cocking support (13) to align AR2 with air cylinder rod (12).
 - e. Slightly raise the test unit to align the ball on air cylinder rod (12) with the recess in the piston rod of the test unit where the ball of the power cable connects.
 - f. Close altitude chamber lid (1).

NOTE

Leave the AR2 JUMP/OFF switch in the OFF position at all times during these tests.

**TEST CHAMBER ASSEMBLY, MODEL 452
OPERATION UNDER USUAL CONDITIONS - CONT**

0009 00

INITIAL ADJUSTMENT BEFORE USE – CONT

2. Verify that ON/OFF switch (5) of the test chamber is in OFF position and CLIMB/FALL/COCK switch (8) in FALL position (centered).
3. Plug power cord (16) into 110 VAC outlet.

NOTE

Record test data on maintenance log (WP 0042 00).

CAUTION

To avoid damaging the test chamber do not switch the test chamber on/off switch to on while the air compressor or vacuum pump is under load (while the altitude chamber is under vacuum or the air cylinder is pressurized). If it has recently been used, wait one to two minutes for pressure trapped in the system to bleed off.

4. Position ON/OFF switch (5) on test chamber to ON. The indicator light (6) will illuminate, and the air compressor and vacuum pump will start. When switching the test chamber ON, immediately look under the transparent altitude chamber at the ends of both air compressor and vacuum pump to ensure that the cooling fans are spinning on both units. If either fan is not spinning, immediately cycle the CLIMB/FALL/COCK switch (8) between FALL and COCK until the fans spin. Move the CLIMB/FALL/COCK switch (8) on test chamber to CLIMB position and adjust the altitude control regulator (14) to an altitude of 6,500 feet.

NOTE

Pressure vs. rate of fall varies greatly with altitude; as altitude increases, the rate of fall will also increase for a given pressure reading on the gauge. To be sure of the exact rate of fall, always check it with a stop watch over the 1,000-foot interval from 500 feet above to 500 feet below the dial setting of the AR2.

NOTE

Check pressure vs. rate of fall values shown on FUNCTIONS decal once each hour with a stop watch to verify accuracy. These checks should be conducted between 6,000 and 5,000 feet simulated altitude with a barometric pressure adjustment of 29.92 on the altimeter. Values shown on the FUNCTIONS decal correspond approximately to rate of fall indicated thereon. The AR2 rate-of-fall mechanism senses rate of pressure change (PSI/sec), which corresponds to its rate of fall. To obtain correct rate-of-fall data, always install an AR2 in the altitude chamber before testing.

NOTE

It is not necessary to wait for the AR2 to stabilize since these checks do not result in actuation.

**TEST CHAMBER ASSEMBLY, MODEL 452
OPERATION UNDER USUAL CONDITIONS**

0009 00

INITIAL ADJUSTMENT BEFORE USE

5. Turn the PRESSURE CONTROL regulator (10) on the test chamber fully counterclockwise to its stop.

NOTE

If the test chamber will not maintain altitude, there is a leak in the pneumatic system. Ensure that compression nuts are hand tight and that the altitude chamber gasket is not damaged. DO NOT USE WRENCHES. If the chamber still does not maintain altitude, send it back to depot for repair.

6. Move the CLIMB/FALL/COCK switch (8) on the test chamber to FALL position. Verify that the altitude reading remains at 6,500 feet or that it falls less than 100 feet in ten seconds.
7. Move the CLIMB/FALL/COCK switch (8) to CLIMB.
8. Turn the PRESSURE CONTROL regulator (10) on the test chamber clockwise to obtain 15 PSI on the PRESSURE GAGE (11).
9. Move the CLIMB/FALL/COCK switch (8) on the test chamber to FALL and, using a stopwatch, record the time it takes for the altimeter to fall from 6,000 to 5,000 feet.
10. Calculate the rate of fall in ft/sec by dividing 1,000 by the stopwatch time. Using an erasable marker, soft pencil, or other suitable instrument, transfer the pressure value from the PRESSURE GAGE (11) and the rate of fall to the appropriate spaces on the FUNCTIONS decal (9) on the test chamber.
11. Move the CLIMB/FALL/COCK switch (8) to CLIMB.
12. Change the reading on the PRESSURE GAGE (11) to a higher or lower value as required.
13. Repeat steps 9 through 12 as required to obtain rate of fall information within the desired range.

CAUTION

To protect altimeter from damage, do not press rapid fall dump switch at altitudes greater than 25,000 feet.

14. Move CLIMB/FALL/COCK switch (8) to FALL, and increase pressure in altitude chamber to ambient by holding down on RAPID FALL DUMP switch (7).
15. Position test chamber ON/OFF switch (5) to OFF.
16. Open lid (1) of altitude chamber and remove AR2 (3).
17. Prepare AR2 for storage or movement (WP 0023 00).
18. Altimeter calibration. If altimeter (4) calibration is required, refer to (WP 0021 00 for removal and replacement.

**TEST CHAMBER ASSEMBLY, MODEL 452
OPERATION UNDER USUAL CONDITIONS - CONT**

0009 00

OPERATING PROCEDURE

NOTE

Operating procedure for the Model 452 test chamber Assembly consists of evaluation testing of the AR2.

1. Verify that the AR2 JUMP/OFF switch is in OFF position, the storage cable and piston rod cap are removed, refer to WP 0008 00, and that AR2 is cocked.

WARNING

If there is any indication of a leak in the aneroid, remove the AR2 from service. A leaking aneroid may cause a malfunction which may result in death of parachutist.

2. Check the AR2 for aneroid leakage at ground level before testing (WP 0008).

NOTE

Ensure that the AR2 is cocked and the piston rod cap is removed before performing test procedure.

3. Set AR2 attitude dial to 5,500 feet.
4. Install AR2 in the test chamber (Refer to initial adjustments before use).

CAUTION

To avoid damage to test chamber do not switch it on while the air compressor or vacuum pump is under load (while the altitude chamber is under vacuum or the air cylinder is pressurized). If it has recently been used, wait one to two minutes for pressure trapped in the system to bleed off.

5. Switch ON the test chamber. The indicator light (6) will illuminate, and the air compressor and vacuum pump will start. When switching the test chamber ON, immediately look under the transparent altitude chamber at the ends of both the air compressor and vacuum pump to ensure that the cooling fans are spinning on both units. If either of the fans is not spinning, immediately cycle the CLIMB/FALL/COCK switch (8) between Fall and Cock until the fans spin.

WARNING

Do not move climb/fall/cock switch on test chamber to cock unless AR2 JUMP/OFF switch is in the fully off position. Attempting to cock the mechanism with the switch in an intermediate position may damage internal components and render the AR2 inoperative. This will prevent deployment of a parachute and may result in death of parachutist.

**TEST CHAMBER ASSEMBLY, MODEL 452
OPERATION UNDER USUAL CONDITIONS**

0009 00

OPERATING PROCEDURE**NOTE**

The end of the AR2 piston rod will be visible when the AR2 is cocked.

6. Move the CLIMB/FALL/COCK switch (8) on test chamber to COCK for two seconds. Since the AR2 is already cocked, nothing will happen. On subsequent tests, after actuating the test unit, it will be necessary to recock the test unit by moving the CLIMB/FALL/COCK switch (8) to COCK.

CAUTION

Climb rates or fall rates greater than 833 ft/sec may cause damage to the altimeter.

NOTE

When conducting tests with AR2 dial settings greater than 15,000 feet, increase the wait time from 30 or more seconds to 40 or more seconds once the desired altitude is reached. Inadequate wait time can result in erroneous test results.

7. Move the CLIMB/FALL/COCK switch (8) on test chamber to CLIMB position. Adjust the pressure control regulator (14) on the test chamber to the desired altitude as observed on the altimeter (4). This altitude should be at least 2,000 feet above the altitude set on the altitude dial (refer to step 3). Once the desired altitude is reached, wait 30 or more seconds for the unit to stabilize. This allows pressure trapped in the rate-of-fall sensing chamber of the AR2 to bleed off so that it comes to the same pressure as the surrounding environment. This will allow the rate of fall mechanism to function properly.

CAUTION

Do not select a rate of fall between 65 and 85 ft/sec. Repeated testing between these values will cause excessive wear to the rate-of-fall mechanism of the AR2 and result in malfunctions.

NOTE

The barometric pressure adjustment setting on the altimeter on the test chamber shall always remain at 29.92 to assure correct readings of altitude with respect to mean sea level.

NOTE

Values shown on FUNCTIONS decal on test chamber correspond approximately to rates of fall indicated thereon. The exact rate of fall during testing should always be determined with the aid of a stop watch.

8. Turn the PRESSURE CONTROL regulator (10) on the test chamber console to adjust the rate of pressure increase inside the altitude test chamber. Adjust pressure as observed on the pressure (PSI) gage (11) of the test chamber to a pressure corresponding to a rate of fall of 85 to 90 ft/sec. The rate of fall should be established between 6,000 and 5,000 feet.

OPERATING PROCEDURE – CONT

9. Rotate altitude chamber switch lever (2) on test chamber counterclockwise 180°. This will put the AR2 JUMP/OFF switch in JUMP position.

NOTE

AR2 functional test requirements are summarized in the following table.

AR2 FUNCTIONAL TESTS

TYPE OF TEST	AR2 DIAL SETTING	RATE OF FALL		ACTUATION ALTITUDE TOLERANCE
		RATE OF FALL	ALTITUDE AT WHICH MEASURED	
Rate of fall Mechanism Verification:				
Fire Test	5,500 ft	85/90 fps	6,000/5,000 ft	± 300 ft
No Fire Test	5,500 ft	60/65 fps	6,000/5,000 ft	No fire
No Fire Test	10,500 ft	60/65 fps	11,000/10,000 ft	No fire
Altitude Actuation Verification:				
Fire Test	3,000 ft	100/120 fps	3,500/2,500 ft	± 300 ft
Fire Test	8,000 ft	100/120 fps	8,500/7,500 ft	± 300 ft
Fire Test	15,000 ft	100/120 fps	15,500/14,500 ft	± 500 ft
Fire Test	Required Actuation Altitude, MSL*	100/120 fps	Required Actuation Altitude ± 500 ft	± 300 ft or ± 500 ft

* See step 15.

10. Move the test chamber CLIMB/FALL/COCK switch (8) to FALL position. As altitude decreases, as observed on the test chamber altimeter (4), check for the altitude at which the AR2 actuates. Actuation of the AR2 should occur a 5,500 feet ± 300 feet. Testing under the conditions described in step 8 constitutes a fire test for the rate of fall mechanism verification.

NOTE

It is not necessary to dump the altitude test chamber if a retest at the same altitude is desired.

11. After actuation, if a retest is desired, proceed as follows:

CAUTION

To avoid damage to the AR2 under test, never rotate altitude chamber switch lever with the CLIMB/FALL/COCK switch in the cock position.

**TEST CHAMBER ASSEMBLY, MODEL 452
OPERATION UNDER USUAL CONDITIONS**

0009 00

OPERATING PROCEDURE

12. Rotate the altitude chamber switch lever (2) clockwise 180°. This will move the AR2 JUMP/OFF switch to OFF position.
13. Repeat steps 6 through 10.

WARNING

If malfunctions of the rate-of-fall mechanism occur, or if actuation altitude deviates from the dial setting by more than the prescribed tolerance, remove the AR2 from service.

14. To complete the test for rate-of-fall mechanism verification:
 - a. Conduct a no-fire test using the above procedure. Leave the altitude dial set at 5,500 feet and set the rate of fall between 60 and 65 ft/sec. The rate of fall should be established between 6,000 and 5,000 feet. Actuation of the AR2 should not occur at any altitude.
 - b. Conduct a second no-fire rate of fall test with the AR2 altitude dial set to 10,500 feet. Set the rate of fall between 60 and 65 ft/sec. The rate of fall should be established between 11,000 and 10,000 feet. Actuation of the AR2 should not occur at any altitude.
15. To conduct actuation altitude tests:
 - a. Set the AR2 dial to 3,000 feet. Set the rate of fall between 100 and 120 ft/sec. The rate of fall should be established between 3,500 and 2,500 feet. Actuation of the AR2 should occur at 3,000 feet \pm 300 feet.
 - b. Set the AR2 dial to 8,000 feet. Set the rate of fall between 100 and 120 ft/sec. The rate of fall should be established between 8,500 and 7,500 feet. Actuation of the AR2 should occur at 8,000 \pm 300 feet.
 - c. Set the AR2 dial to 15,000 feet. Set the rate of fall between 100 and 120 ft/sec. The rate of fall should be established between 15,500 and 14,500 feet. Actuation of the AR2 should occur at 15,000 feet \pm 500 feet.
 - d. Set the AR2 dial to the MSL altitude where actuation is required for a normal mission profile. Set the rate of fall between 100 and 120 ft/sec. The rate of fall should be established between 500 feet above and 500 feet below the dial setting. The altitude actuation tolerance is \pm 300 feet for dial settings below 10,000 feet MSL and \pm 500 feet for settings of 10,000 or above.

CAUTION

To protect altimeter from damage, do not press RAPID FALL DUMP switch at altitudes greater than 25,000 feet.

16. Depress and hold the RAPID FALL DUMP switch (7) until the test chamber is dumped.

TEST CHAMBER ASSEMBLY, MODEL 452
OPERATION UNDER USUAL CONDITIONS - CONT

0009 00

OPERATING PROCEDURE - CONT

17. Rotate Test Altitude Chamber switch lever (2) clockwise 180°. This will put the AR2 JUMP/OFF switch in OFF position.
18. Recock the AR2.
19. Remove the AR2 from the test chamber.
20. Switch test chamber ON/OFF switch (5) to off.
21. Install power cable or prepare AR2 for storage or movement (WP 0023 00).

DECALS AND INSTRUCTION PLATES

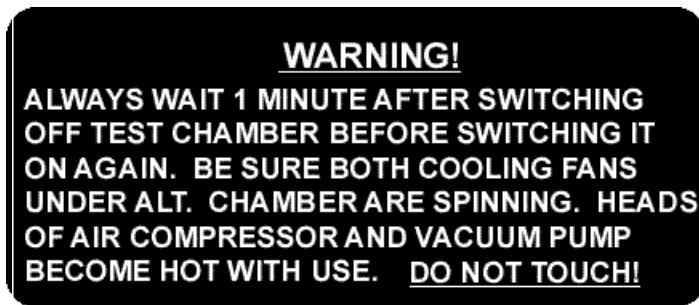

45-0062P

WARNING decal gives operational warnings to operator (for location, refer to Page 2, WP 0007 00).

**TEST CHAMBER ASSEMBLY, MODEL 452
OPERATION UNDER USUAL CONDITIONS**

0009 00

DECALS AND INSTRUCTION PLATES

PRESSURE CONTROL		RAPID FALL		● CLIMB
				● FALL
				● COCK
PRESSURE (PSI)	FALL RATE (FT/SEC) 6000-5000FT			
	APPROX			
	APPROX			
	APPROX			
	APPROX			
	APPROX			
	APPROX			
	APPROX			
	APPROX			
ALTITUDE CONTROL				
← INCREASE	↓	DECREASE →		

42500 11P

Functions decal provides a place to record pressures and fall rate (for location, refer to page 2, WP 0007 00.

TEST CHAMBER ASSEMBLY, MODEL 452
OPERATION UNDER USUAL CONDITIONS - CONT

0009 00

DECALS AND INSTRUCTION PLATES

FUNCTIONS decal provides a place to record pressures and fall rate (for location refer to Page 2, WP 0007 00).



TEST CHAMBER ASSEMBLY, AR2, MODEL 452 identification decal (for locations, refer to Page 2, WP 0007 00).

TEST CHAMBER ASSEMBLY, MODEL 452
OPERATION UNDER USUAL CONDITIONS

0009 00

DECALS AND INSTRUCTION PLATES

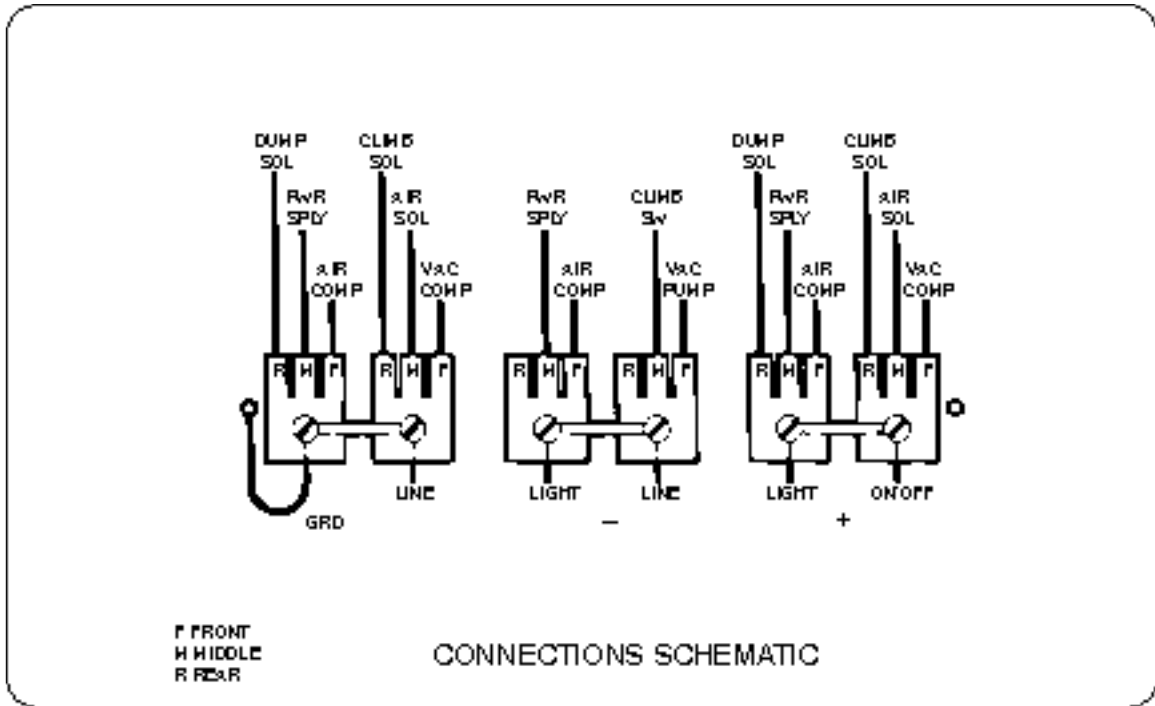

425 0025P

CONNECTIONS SCHEMATIC decal provides identification of electrical connections (for location, refer to Page 2, WP 0007 00).

PREPARATION FOR MOVEMENT

If necessary, open altitude chamber lid and remove AR2.

Prepare AR2 for storage or shipment (refer to WP 0023 00).

Disconnect control assembly power cable from 110 VAC outlet. Coil power cable behind control assembly.

WARNING

The test chamber and carrying case weighs 70 lbs. The test chamber weighs 50 lbs. Use two persons or lifting device when moving or lifting to prevent injury to personnel.

Install test chamber in carrying case. Close and lock carrying case lid.

THIS PAGE INTENTIONALLY LEFT BLANK

**ELECTRONIC TEST CHAMBER ASSEMBLY, MODEL 453
OPERATION UNDER USUAL CONDITIONS**

0010 00

SITING REQUIREMENTS

The test chamber requires bench space approximately 36 inches wide by 30 inches deep with 110 VAC, 50/60 Hz power source within six feet of the unit.

SHELTER REQUIREMENT

The test chamber shall be contained in a building that meets storage requirements outlined in TM 10-1670-201-23, T.O. 13C-1-41, or NAVAIR 13-1-17, at an altitude between 0 (feet) and 30,000 (feet) above MSL. Temperature shall be between +41°F (+5°C) and +122 F (+50°C).

ASSEMBLY AND PREPARATION FOR USE

The test chamber carrying case is used for movement and storage of the test chamber. No external packaging is required.

WARNING

The test chamber and carrying case weight is 60 lbs. The test chamber weighs 42 lbs. Use two persons or lifting device when moving or lifting to prevent injury to personnel.

Open test chamber carrying case cover. Lift and remove test chamber from carrying case (WP 0003 00). Place test chamber on work bench.

Check for loose or missing hardware or decals. Assure that all adjustable knobs and switches are present and operating without binding. Check for broken or damaged displays. Check for damage to altitude chamber, lid and gasket. Retain carrying case for future storage or movement of unit.

INITIAL ADJUSTMENT BEFORE USE

CAUTION

Do not transport or store AR2 without piston rod cap or power cable attached. External forces or impacts applied to the piston rod may cause unit to malfunction. Any AR2 subjected to external forces or impact must be tested and, if necessary, removed from service.

Do not operate test chamber while in the carrying case. Components will overheat and may become damaged.

NOTE

To obtain correct rate-of-fall data, always install an AR2 in the altitude chamber before testing.

**ELECTRONIC TEST CHAMBER ASSEMBLY, MODEL 453
OPERATION UNDER USUAL CONDITIONS - CONT**

0010 00

INITIAL ADJUSTMENT BEFORE USE - CONT

NOTE

Ensure that the test chamber is in calibration (WP 0018 00).

1. For all testing, an AR2 shall be installed in the altitude chamber.
2. If necessary, set AR2 JUMP/OFF switch to OFF. Set altitude dial to 1000 feet. Cock AR2 and remove storage cable and piston rod cap.
3. Open altitude chamber lid (2). Position the cocking support (3) and install the AR2. Align AR2 JUMP/OFF switch lever with altitude chamber switch lever.
4. Close altitude chamber lid.

NOTE

The unit shall be turned on and warmed up for 30 minutes minimum before beginning any tests.

5. Plug power cord into 110 VAC 50/60 Hz outlet.
6. When ready to start test, position control assembly ON/OFF switch (21) to ON. When switching test chamber on, immediately look at the end of vacuum pump/air compressor to ensure that the cooling fan is spinning. If fan is not spinning, immediately press and release HOLD DOWN TO COCK switch several times until fan spins.

ALTITUDE STABILITY TEST

1. If necessary, press DUMP switch (15) to extinguish CHAMBER VENTED indicator (16). Press RESET DISPLAYS switch.
2. Press and hold HOLD DOWN TO SET switch (13). Use SET ALTITUDE control (4) to set altitude to 2000 ± 10 feet as observed on ALTITUDE (FT MSL) display (20). Release HOLD DOWN TO SET switch (13).
3. Press and hold HOLD DOWN TO SET switch (13). Turn SET FALL RATE control (5) fully counter-clockwise.
4. If necessary, reset ALTITUDE (FT MSL) display (20) to 2000 ± 10 feet. Release HOLD DOWN TO SET switch (13).
5. Record altitude reading.
6. Wait three minutes.
7. Record altitude reading.

**ELECTRONIC TEST CHAMBER ASSEMBLY, MODEL 453
OPERATION UNDER USUAL CONDITIONS**

0010 00

ALTITUDE STABILITY TEST

8. Press DUMP switch (15); wait one second and press DUMP switch again.
9. Wait for displays to stabilize.
10. Record altitude reading.
11. All three altitude readings shall be within ten feet.
12. Repeat steps 2 thru 11 at 15,000 ± 10 feet and at 35,000 ± 10 feet.
13. If no other tests are to be performed follow shut down after testing procedures at end of this work package.

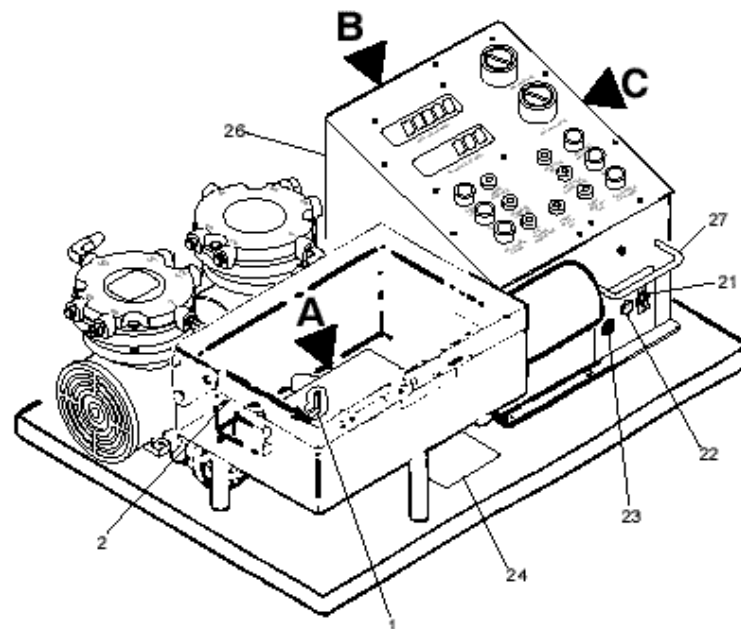
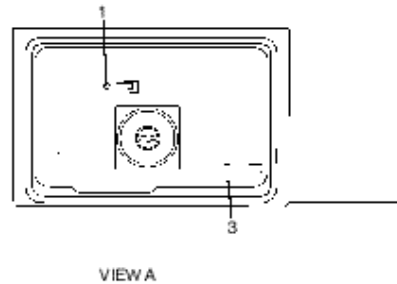
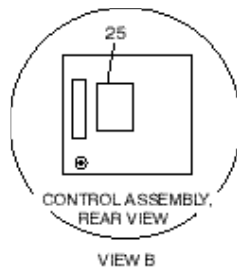

425-0264P

ELECTRONIC TEST CHAMBER ASSEMBLY, MODEL 453
OPERATION UNDER USUAL CONDITIONS - CONT

0010 00

ALTITUDE STABILITY TEST - CONT

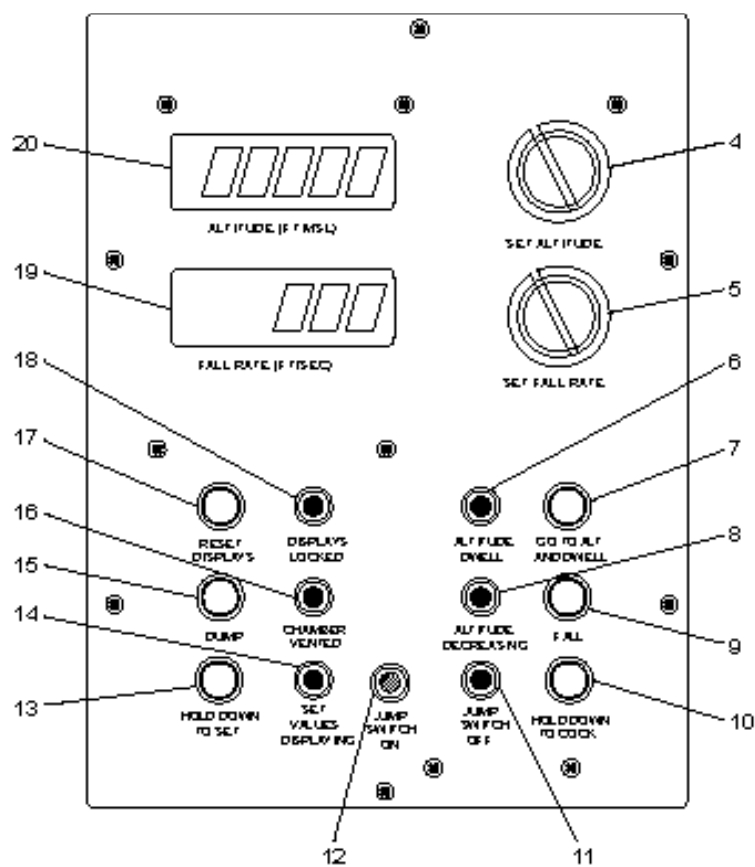

VIEW C

LEGEND

- | | |
|---|---|
| <ul style="list-style-type: none"> 1. ALTITUDE CHAMBER Switch Lever 2. Chamber Lid 3. Cocking Support 4. SET ALTITUDE Control 5. SET FALL RATE Control 6. ALTITUDE DWELL Indicator 7. GO TO ALT AND DWELL Switch 8. ALTITUDE DECREASING Indicator 9. FALL Switch 10. HOLD DOWN TO COCK Switch 11. JUMP SWITCH OFF Indicator 12. JUMP SWITCH ON Indicator 13. HOLD DOWN TO SET Switch | <ul style="list-style-type: none"> 14. SET VALUES DISPLAYING Indicator 15. DUMP Switch 16. CHAMBER VENTED Indicator 17. RESET DISPLAYS Switch 18. DISPLAYS LOCKED Indicator 19. FALL RATE (FT/SEC) Display 20. ALTITUDE (FT MSL) Display 21. ON/OFF Switch 22. Fuse 23. Calibration Port 24. Identification Decal (2 required) 25. Control Assembly Decal 26. Control Assembly 27. Lifting Handle |
|---|---|

425-0027P

**TEST CHAMBER ASSEMBLY, MODEL 453
OPERATION UNDER USUAL CONDITIONS**

0010 00

FALL RATE TEST**RANGE**

1. Obtain a timer (stop watch).
2. Press and hold HOLD DOWN TO SET switch (13), use SET ALTITUDE control (4) to set altitude to 3000 ± 100 feet as observed on ALTITUDE (FT MSL) display (20). Release HOLD DOWN TO SET switch (13).
3. Press and hold HOLD DOWN TO SET switch (13); use SET FALL RATE control (5) to achieve 26 ± 1 ft/sec fall rate as observed on FALL RATE (FT/SEC) display (19). Release HOLD DOWN TO SET switch (13).
4. Press GO TO ALT AND DWELL switch (7).
5. When ALTITUDE DWELL indicator (6) stops flashing, use altitude chamber switch lever (1) to set AR2 JUMP/OFF switch to JUMP.
6. Press FALL switch (9). Set AR2 JUMP/OFF switch to OFF.
7. At first reading below 2000 feet start timer and record altitude. At first reading below 1000 feet, stop timer and record altitude.
8. Difference between two altitude readings divided by the time equals the fall rate. Fall rate shall be less than 30 ft/sec.
9. Repeat step 2 using 4000 ± 100 feet.
10. Repeat step 3 using 225 ± 1 ft/sec.
11. Press GO TO ALT AND DWELL switch (7).
12. When ALTITUDE DWELL indicator (6) stops flashing set AR2 JUMP/OFF switch to JUMP.
13. Press FALL switch (9); set AR2 JUMP/OFF switch to OFF.
14. At first reading below 2000 feet start timer and record altitude. At first reading below 1000 feet, stop timer and record altitude.
15. Difference between two altitude readings divided by the time equals the fall rate. Fall rate shall be greater than 200 ft/sec.
16. Repeat steps 2 through 15 using a preset altitude of 27,000 feet for the 26 ft/sec test and 28,000 feet for the 225 ft/sec test. Determine the fall rate between 26,000 feet and 25,000 feet for both tests.
17. If no other tests are to be performed, follow shut down after testing procedures at end of this work package.

FALL RATE TEST - CONT

SELECTOR ACCURACY

1. Press and hold HOLD DOWN TO SET switch (13), use SET ALTITUDE control (4) to set altitude to 7500 ± 100 feet as observed on ALTITUDE (FT MSL) display (20). Release HOLD DOWN TO SET switch (13).
2. Press and hold HOLD DOWN TO SET switch (13), use SET FALL RATE control (5) to achieve 62.5 ± 0.5 ft/sec fall rate as observed on FALL RATE (FT/SEC) display (19). Release HOLD DOWN TO SET switch (13).
3. Press GO TO ALT AND DWELL switch (7).
4. When altitude dwell indicator (6) stops flashing, set AR2 JUMP/OFF switch to JUMP.
5. Press FALL switch (9). Set AR2 JUMP/OFF switch to OFF.
6. At first altitude reading below 6500 feet, start timer and record altitude.
7. At first altitude reading below 4500 feet, stop timer and record altitude.
8. Difference between two altitude readings divided by the time equals the fall rate
9. Press GO TO ALT AND DWELL switch (7). Wait until ALTITUDE DWELL indicator (6) stops flashing.
10. Set AR2 JUMP/OFF switch to JUMP; press FALL switch (9).
11. Set AR2 JUMP/OFF switch to OFF; observe and record fall rate on FALL RATE (FT/SEC) display (17) at approximately 5500 feet.
12. Repeat step 2 using 87.5 ± 0.5 ft/sec.
13. Repeat steps 3 through 11.
14. Repeat step 1 using $12,500 \pm 100$ feet. Leave fall rate set at 87.5 ± 0.5 ft/sec.
15. Press GO TO ALT AND DWELL switch (7).

**ELECTRONIC TEST CHAMBER ASSEMBLY, MODEL 453
OPERATION UNDER USUAL CONDITIONS**

0010 00

FALL RATE TEST

SELECTOR ACCURACY

16. When ALTITUDE DWELL indicator (6) stops flashing, set AR2 JUMP/OFF switch to JUMP.
17. Press FALL switch (9). Position AR2 JUMP/OFF switch to OFF.
18. At first altitude reading below 11,500 feet, start timer and record altitude.
19. At first altitude below 9500 feet, stop timer and record altitude.
20. Difference between two altitude readings divided by the time equals the fall rate.
21. Press GO TO ALT AND DWELL switch (7). Wait until ALTITUDE DWELL indicator (6) stops flashing.
22. Set AR2 JUMP/OFF switch to JUMP; press FALL switch (9).
23. Set AR2 JUMP/OFF switch to OFF; observe and record fall rate on FALL RATE (FT/SEC) display (17) at approximately 10,500 feet.
24. Repeat step 2 using 62.5 ± 0.5 ft/sec.
25. Repeat steps 15 through 23.
26. Neither the calculated fall rate nor the displayed fall rate may differ from the set rate by more than 2 ft/sec for any of the four tests.
27. If no other tests are to be performed, follow shut down after testing procedures at the end of this work package.

CONTROL INTERLOCKS TEST

This is an optional test to verify correct function of switches and indicators.

1. Set AR2 altitude dial to 1,000 feet and install AR2 in altitude chamber.
2. If DISPLAYS LOCKED indicator (18) is illuminated, press RESET DISPLAYS switch (17).
3. If CHAMBER VENTED indicator (16) is illuminated, press DUMP switch (15).
4. Press and hold HOLD DOWN TO SET switch (13); use SET ALTITUDE control (4) to set altitude to 3000 ± 100 feet as observed on ALTITUDE (FT MSL) display (20); release HOLD DOWN TO SET switch.
5. Press and hold HOLD DOWN TO SET switch (13); use SET FALL RATE control (5) to achieve fall rate of 100 ± 10 ft/sec as observed on FALL RATE (FT/SEC) display (19); Release HOLD DOWN TO SET switch.
6. Press GO TO ALT AND DWELL switch. Before ALTITUDE DWELL indicator (6) stops flashing, set AR2 JUMP/OFF switch to JUMP; press FALL switch (9).
7. The test chamber shall not indicate a fall.
8. Wait until ALTITUDE DWELL indicator (6) stops flashing, Set AR2 JUMP/OFF switch to OFF. Press FALL switch (9).
9. The test chamber shall not indicate a fall.
10. Set AR2 JUMP/OFF switch to JUMP. Press FALL switch (9).
11. The test chamber will indicate a fall and the AR2 will actuate. The DISPLAYS LOCKED indicator (18) will illuminate. Press RESET DISPLAYS switch (17).
12. The display shall not reset; DISPLAYS LOCKED indicator (18) shall remain illuminated.
13. Press HOLD DOWN TO COCK switch (10).
14. The AR2 shall not cock.
15. Set AR2 JUMP/OFF switch to intermediate position (neither JUMP SWITCH indicator lit). Press HOLD DOWN TO COCK switch (10).
16. The AR2 shall not cock.
17. Set AR2 JUMP/OFF switch to OFF. Press and hold HOLD DOWN TO COCK switch (10).
18. AR2 shall cock. Release HOLD DOWN TO COCK switch.

**ELECTRONIC TEST CHAMBER ASSEMBLY, MODEL 453
OPERATION UNDER USUAL CONDITIONS**

0010 00

CONTROL INTERLOCKS TEST

19. Press GO TO ALT AND DWELL switch (7).
20. ALTITUDE DWELL indicator (6) shall flash. DISPLAYS LOCKED indicator (18) shall remain illuminated and displays shall not reset.
21. Wait until ALTITUDE DWELL indicator (6) stops flashing. Set AR2 JUMP/OFF switch to JUMP. Press FALL switch (9).
22. The test chamber shall not indicate a fall.
23. Press RESET DISPLAYS switch (17).
24. ALTITUDE (FT MSL) display (20) shall reset to 3000 feet (value set previously). FALL RATE (FT/SEC) display shall show approximately zero.
25. Set AR2 JUMP/OFF switch to OFF.
26. All interlocks and indicators shall function as described above or the test chamber is defective and must be returned to depot for repair.

OPERATING PROCEDURE

NOTE

Operating Procedures for the ELECTRONIC TEST CHAMBER ASSEMBLY, MODEL 453 consist of evaluation testing of the AR2.

1. Verify that the JUMP/OFF switch is in OFF position, the storage cable and piston rod cap are removed, and that AR2 is cocked.

WARNING

If there is any indication of a leak in the aneroid, remove the AR2 from service. A leaking aneroid may cause a malfunction which may result in death of parachutist.

2. Check the AR2 for aneroid leakage at ground level before testing (WP 0008).

NOTE

AR2 functional test requirements are summarized in table below.

AR2 FUNCTIONAL TESTS

TYPE OF TEST	AR2 DIAL SETTING	RATE OF FALL	ALTITUDE ACTUATION TOLERANCE
Rate threshold Verification:			
Fire Test	5,500 ft	85/90 fps	± 300 ft
No Fire Test	5,500 ft	60/65 fps	No fire
No Fire Test	10,500 ft	60/65 fps	No fire
Altitude Actuation Verification:			
Fire Test	3,000 ft	100/120 fps	± 300 ft
Fire Test	8,000 ft	100/120 fps	± 300 ft
Fire Test	15,000 ft	100/120 fps	± 500 ft
Fire Test	Required Actuation Altitude, MSL*	100/120 fps	± 300 ft or ± 500 ft

* See paragraph 13 of Actuation Altitude Test.

**ELECTRONIC TEST CHAMBER ASSEMBLY, MODEL 453
OPERATION UNDER USUAL CONDITIONS**

0010 00

OPERATING PROCEDURE

RATE THRESHOLD (ALL FIRE) TEST

1. Install AR2 in test chamber.
2. After test chamber warm-up, ensure DISPLAYS LOCKED indicator (18) and CHAMBER VENTED indicator (16) are extinguished. If not, press RESET DISPLAYS switch (17).
3. Set AR2 altitude dial to 5500 feet. Close altitude chamber lid (2).
4. Press and hold HOLD DOWN TO SET switch (13) and use SET ALTITUDE control (4) to set Test Chamber altitude to 7500 ± 100 feet. Release HOLD DOWN TO SET switch (13).
5. Press and hold HOLD DOWN TO SET switch (13) and use SET FALL RATE control (5) to set fall rate at 87.5 ± 0.5 ft/sec. Release HOLD DOWN TO SET switch (13).
6. If ALTITUDE DWELL indicator (6) is not illuminated or flashing, press GO TO ALT AND DWELL switch (7). Wait until ALTITUDE DWELL indicator (6) stops flashing.
7. Set AR2 JUMP/OFF switch to JUMP. Press FALL switch (9).
8. The AR2 shall actuate within 300 feet of AR2 dial setting.
9. Set AR2 JUMP/OFF switch to OFF, press HOLD DOWN TO COCK switch (10), and observe movement of piston rod to right until AR2 cocks.
10. If required, repeat steps 2 through 9.
11. If no other tests are to be performed, follow shut down after testing procedures at end of this work package.

RATE THRESHOLD (NO FIRE) TEST

1. Ensure DISPLAYS LOCKED and CHAMBER VENTED indicators (16, 18) are extinguished. If not, press RESET DISPLAYS switch (17).
2. Set AR2 altitude dial to 5500 feet. Close altitude chamber lid (2).
3. Press and hold HOLD DOWN TO SET switch (13) and set Test Chamber altitude to 7500 ± 100 feet. Release HOLD DOWN TO SET switch (13).
4. Press and hold HOLD DOWN TO SET switch (13) and set fall rate at 62.5 ± 0.5 ft/sec. Release HOLD DOWN TO SET switch (13).
5. If ALTITUDE DWELL indicator (6) is not illuminated or flashing, press GO TO ALT AND DWELL switch (7). Wait until ALTITUDE DWELL indicator (6) stops flashing.
6. Set AR2 JUMP/OFF switch to JUMP. Press FALL switch (9). Wait until the altitude as observed on the ALTITUDE (FT MSL) display (20) reaches 4500 feet.

OPERATING PROCEDURE

RATE THRESHOLD (NO FIRE) TEST - CONT

7. The AR2 shall not actuate.
8. Set AR2 JUMP/OFF switch to OFF.
9. Repeat steps 2 through 8 using AR2 altitude dial setting of 10,500 feet, test chamber altitude setting of 12,500 feet, and same fall rate setting. For this step, set AR2 JUMP/OFF switch to OFF when altitude reaches 9,500 feet.
10. If no other tests are to be performed, follow shut down after testing procedure at end of this work package.

ACTUATION ALTITUDE TEST

1. Ensure CHAMBER VENTED indicator (16) and DISPLAYS LOCKED indicator (18) are extinguished.
2. Set AR2 altitude dial to 3000 feet. Close altitude chamber lid (2).
3. Press and hold HOLD DOWN TO SET switch (13); and set altitude to 5000 ± 100 feet. Release HOLD DOWN TO SET switch (13).
4. Press and hold HOLD DOWN TO SET switch (13); and set fall rate to 110 ± 10 ft/sec. Release HOLD DOWN TO SET switch (13).
5. If ALTITUDE DWELL indicator (6) is not illuminated or flashing, press GO TO ALT AND DWELL switch (7). Wait until ALTITUDE DWELL indicator (6) stops flashing.
6. Set AR2 JUMP/OFF switch to JUMP. Press FALL switch (9).
7. Wait for AR2 to actuate and DISPLAYS LOCKED indicator (18) to illuminate.
8. Observe ALTITUDE (FT MSL) display (20) and FALL RATE (FT/SEC) display (19).
9. The AR2 must actuate within 300 feet of AR2 dial setting.
10. Set AR2 JUMP/OFF switch to OFF. Press HOLD DOWN TO COCK switch (10) and observe movement of piston rod to right until AR2 cocks.
11. Repeat steps 1 through 10 using AR2 dial setting of 8000 feet, test chamber altitude setting of 10,000 feet, and same fall rate setting.
12. Repeat steps 1 through 10 using AR2 altitude dial setting of 15,000 feet, test chamber altitude setting of 17,000 feet and same fall rate setting. The altitude actuation tolerance is ± 500 feet for this setting.

**ELECTRONIC TEST CHAMBER ASSEMBLY, MODEL 453
OPERATION UNDER USUAL CONDITIONS**

0010 00

OPERATING PROCEDURE

ACTUATION ALTITUDE TEST

13. Repeat steps 1 through 10 with the AR2 dial set to the MSL altitude where actuation is required for a normal mission profile. Set the test chamber 2,000 feet higher than this altitude with the same fall rate setting. The altitude actuation tolerance is ± 300 feet for dial settings below 10,000 feet MSL and ± 500 feet for settings of 10,000 feet or above.
14. If no other tests are to be performed, follow shut down after testing procedure at end of this work package.

DECALS AND INSTRUCTION PLATES

1. There are two Model 453 identification decals (24). One is located on the mounting board beneath the altitude chamber; the other is mounted on the carrying case.
2. There is one CONTROL ASSEMBLY identification decal (25) located on the back of the control assembly. This decal carries its own serial number; which may differ from the Model 453 serial number.

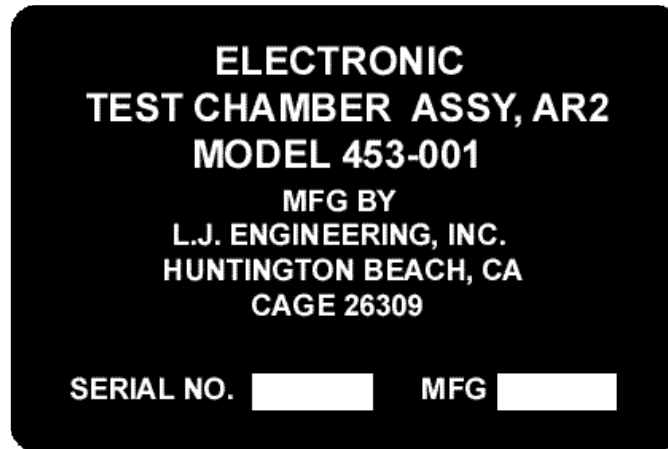

425-0000P

TEST CHAMBER Identification Decal

DECALS AND INSTRUCTION PLATES - CONT

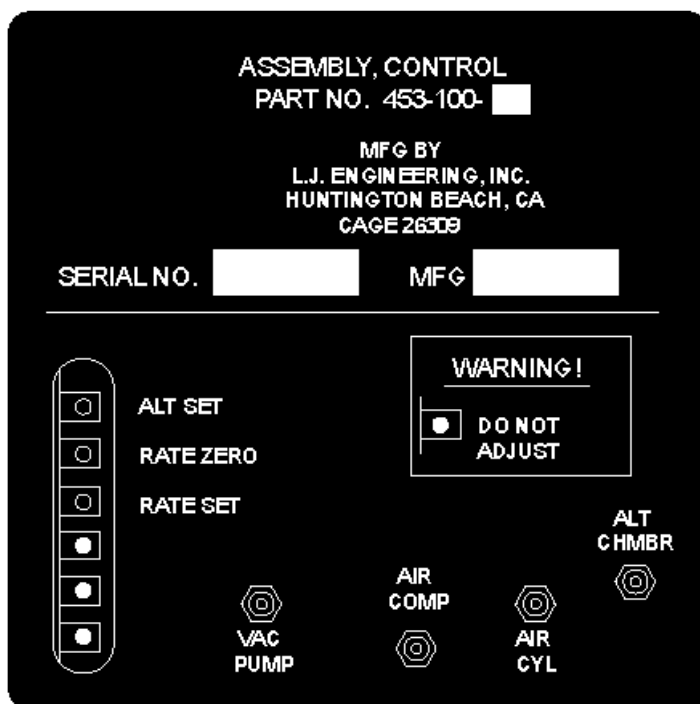

45-4855P

Control Assembly Decal

**ELECTRONIC TEST CHAMBER ASSEMBLY, MODEL 453
OPERATION UNDER USUAL CONDITIONS**

0010 00

SHUT DOWN AFTER TESTING

1. Verify that altitude chamber is at ground level. If required, press DUMP switch (15).
2. Open altitude chamber lid and remove AR2 from altitude chamber.
3. Cocking support shall remain inside the altitude chamber. Close altitude chamber lid.
4. Switch test chamber ON/OFF switch (21) to OFF.
5. Prepare AR2 for storage or shipment (WP 0023 00).

PREPARATION FOR MOVEMENT

1. If necessary, open altitude chamber lid and remove AR2.
2. Prepare AR2 for storage or shipment (refer to WP 0023 00).
3. Disconnect control assembly power cable from 110 VAC outlet. Coil power cable behind vacuum pump/air compressor.

WARNING

The test chamber and carrying case weighs 60 lbs. The test chamber weighs 42 lbs. Use two persons or lifting device when moving or lifting to prevent injury to personnel.

4. Install test chamber in carrying case. Close and lock carrying case lid.

THIS PAGE INTENTIONALLY LEFT BLANK

TESTING AT HIGH ALTITUDE

1. If the test facility is located at high altitude, it may be necessary to conduct tests of the AR2 with dial settings lower than the elevation of the test site. Under such conditions, the pressure inside the altitude chamber will be greater than that outside, and the lid will not stay closed since it has no locks or latches. Nevertheless, testing may be conducted by clamping the lid shut using two standard C-clamps with a 6-inch opening capacity and a throat depth of approximately 3.5 inches. Care must be taken, however, to avoid clamping the lid too tightly.
2. Use the following procedure to obtain the proper clamping force:
 - a. Install the AR2 to be tested in the altitude chamber (refer to WP 0009 00). Close the altitude chamber lid.
 - b. Select an altitude approximately 15,000 feet higher than the test site elevation and cause the chamber to climb to that altitude. This will fully compress the altitude chamber gasket.

CAUTION

Be sure to clamp only the main body of the chamber.

- c. Position the C-clamps as shown, using small pads of cardboard, cloth, or rubber to prevent marring the surfaces of the altitude chamber. Do not clamp fittings, tubing, or any other parts of the chamber which may be damaged.
- d. Tighten the clamps using only enough force to keep them from slipping or moving around on the altitude chamber lid.

WARNING

Do not allow the altitude to fall below 0 feet MSL when the altitude chamber is clamped. Doing so will damage the AAU-31/A altimeter and build up a dangerous level of pressure inside the altitude chamber, which may rupture and cause serious injury to personnel.

3. Any test altitude may now be selected and testing conducted (refer to WP 0009 00). The clamps will prevent the lid from lifting, regardless of the internal pressure.
4. Since the chamber must be opened to change the AR2 dial setting, installing and removing the clamps will slow the testing process. Employ them only when low altitudes can not be reached using normal test procedures.

TESTING AT HIGH ALTITUDE - CONT

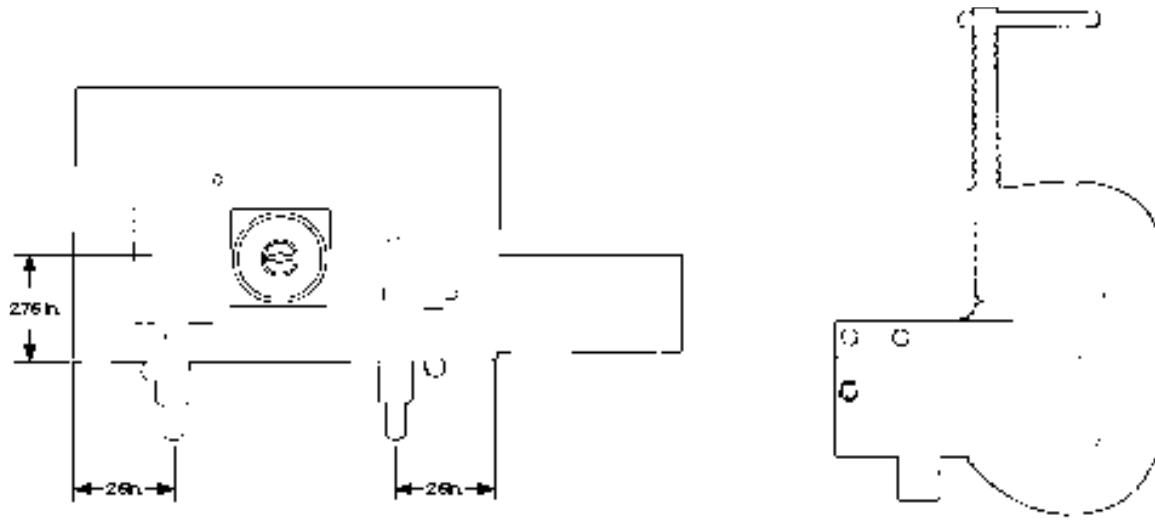

42-000P

**ELECTRONIC TEST CHAMBER ASSEMBLY, MODEL 453
OPERATION UNDER UNUSUAL CONDITIONS (HIGH ALTITUDE FACILITIES)**

0012 00

TESTING AT HIGH ALTITUDE

1. If the test facility is located at high altitude, it may be necessary to conduct tests of the AR2 with dial settings lower than the elevation of the test site. Under such conditions, the pressure inside the altitude chamber will be greater than that outside, and the lid will not stay closed since it has no locks or latches. Nevertheless, testing may be conducted by clamping the lid shut using two standard C-clamps with a 6-inch opening capacity and a throat depth of approximately 3.5 inches. Care must be taken, however, to avoid clamping the lid too tightly.
2. Use the following procedure to obtain the proper clamping force;
 - a. Install the AR2 to be tested in the altitude chamber (refer to WP 0010 00); close the altitude chamber lid.
 - b. Select an altitude approximately 15,000 feet higher than the test site elevation and cause the chamber to climb to that altitude. This will fully compress the altitude chamber gasket.

CAUTION

Be sure to clamp only the main body of the chamber.

- c. Position the C-clamps as shown, using small pads of cardboard, cloth, or rubber to prevent marring the surfaces of the altitude chamber. Do not clamp fittings, tubing, or any other parts of the chamber which may be damaged.
 - d. Tighten the clamps using only enough force to keep them from slipping or moving around on the altitude chamber lid.
3. Any test altitude may now be selected and testing conducted (refer to WP 0010 00). The clamps will prevent the lid from lifting, regardless of the internal pressure.
4. Since the chamber must be opened to change the AR2 dial setting, installing and removing the clamps will slow the testing process. Employ them only when low altitudes cannot be reached using normal test procedures.

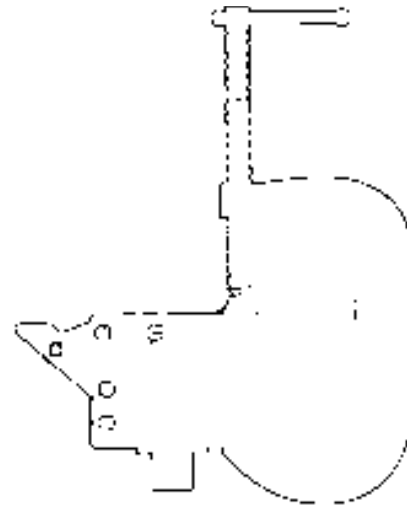
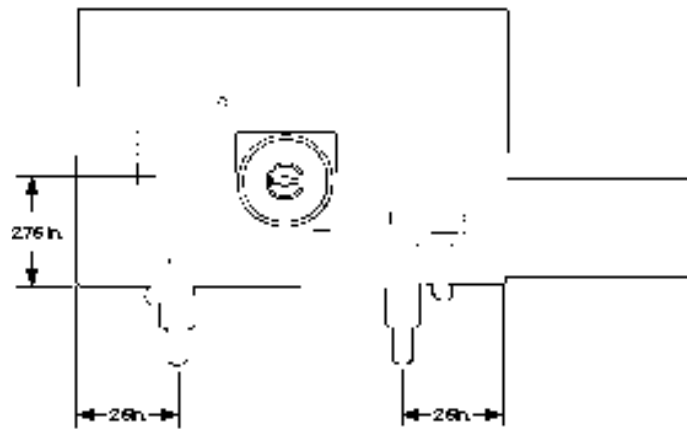

42-0001P

CHAPTER 3

TROUBLESHOOTING PROCEDURES

FOR

AUTOMATIC RIPCORD RELEASE, AR2, MODEL 451

TEST CHAMBER ASSEMBLY, AR2, MODEL 452

ELECTRONIC TEST CHAMBER ASSEMBLY, AR2, MODEL 453

THIS PAGE INTENTIONALLY LEFT BLANK

**TROUBLESHOOTING PROCEDURES
GENERAL INFORMATION**

0013 00

SCOPE OF TASK

Work Package 0014 00 covers troubleshooting procedures for the Model 451. Work Package 0015 00 covers troubleshooting procedures for Model 452 and Model 453. Each work package basically refers to procedures in work packages 0008 00, 0009 00, or 0010 00.

MALFUNCTION/SYMPTOM INDEX, MODEL 451 TROUBLESHOOTING PROCEDURE

- | | |
|---|---------|
| 1. AR2 fails to cock with JUMP/OFF Switch in OFF position. | WP 0014 |
| 2. Aneroid leak check indicator shows incorrect altitude. | WP 0014 |
| 3. JUMP/OFF switch binds or has jerky motion. | WP 0014 |
| 4. Actuates at rates of fall below 65 ft/sec or does not actuate above 85 ft/sec. | WP 0014 |
| 5. Actuates at incorrect altitude. | WP 0014 |

**MALFUNCTION/SYMPTOM INDEX, MODEL 452 TROUBLESHOOTING
PROCEDURE**

- | | |
|---|---------|
| 1. Unit fails to operate. | WP 0015 |
| 2. Either fan fails to spin after repeated attempts. | WP 0015 |
| 3. Altitude chamber does not gain altitude. | WP 0015 |
| 4. Fan is spinning but compressor does not cock AR2 in test chamber. | WP 0015 |
| 5. Pressure gage fails to operate properly and compressor is good. | WP 0015 |
| 6. Altimeter pointer shows jerky motion when displaying falling altitude. | WP 0015 |
| 7. Altimeter does not work. | WP 0015 |

**TROUBLESHOOTING PROCEDURES
GENERAL INFORMATION - CONT**

0013 00

MALFUNCTION/SYMPTOM INDEX, MODEL 453	TROUBLESHOOTING PROCEDURE
1. Unit fails to operate.	WP 0015
2. Fan fails to spin after repeated attempts.	WP 0015
3. Displays garbled or non-functional.	WP 0015
4. Displays will not reset.	WP 0015
5. Panel indicators, controls or electric interlocks do not operate as described.	WP 0015
6. Altitude chamber does not gain or hold attitude.	WP 0015
7. Fan on vacuum pump/compressor is spinning but compressor does not cock AR2 in altitude chamber.	WP 0015
8. Displayed or calculated fall rate deviates from set value by more than 2 ft/sec.	WP 0015

TROUBLESHOOTING PROCEDURES

0014 00

INITIAL SETUP INFORMATION

Maintenance Level

Materials

Maintainer

Model 452 Test Chamber Assembly or Model
453 Electronic Test Chamber Assembly

TABLE 1. TROUBLESHOOTING
AUTOMATIC RIPCORDER RELEASE, MODEL 451

Malfunction	Probable Cause	Corrective Action
1. Fails to cock with JUMP/OFF switch in OFF position.	Defective mechanism	Replace AR2.
2. Aneroid leak check indicator shows incorrect altitude.	Defective aneroid.	Replace AR2.
3. JUMP/OFF switch binds or has jerky motion.	Defective switch.	Replace JUMP/OFF switch. (WP 0020 00)
4. Actuates at rates of fall below 65 ft/sec or does not actuate above 85 ft/sec.	Defective or worn rate-of-fall mechanism.	Replace AR2.
5. Actuates at incorrect altitude (± 300 feet below 10,000 feet MSL; ± 500 feet at 10,000 feet or above).	Defective mechanism or aneroid.	Replace AR2.

END OF WORK PACKAGE

THIS PAGE INTENTIONALLY LEFT BLANK

TROUBLESHOOTING PROCEDURES

0015 00

INITIAL SETUP INFORMATION

**MAINTENANCE
LEVEL**

Maintainer

MATERIALS

Model 451 Automatic Ripcord Release

TABLE 1. TROUBLESHOOTING
TEST CHAMBER ASSEMBLY, MODEL 452

Malfunction	Probable Cause	Corrective Action
1. Unit fails to operate.	<ul style="list-style-type: none"> a. Power cord not plugged in. b. Blown fuse. 	<ul style="list-style-type: none"> a. Plug power cord into 110 VAC, 60 Hz outlet. b. Replace fuse.
2. Either fan fails to spin after repeated attempts.	<ul style="list-style-type: none"> a. Worn or damaged vacuum pump or compressor. 	<ul style="list-style-type: none"> a. Replace vacuum pump or compressor (WP 0021 00).
3. Altitude chamber does not gain altitude.	<ul style="list-style-type: none"> a. Severe leak in system. b. Loose or damaged altitude chamber gasket. c. Damaged vacuum pump chamber. 	<ul style="list-style-type: none"> a. Finger tighten external fittings to chamber and vacuum pump. b. Replace altitude chamber gasket. (WP 0021 00). c. Replace vacuum pump (WP 0021 00).
4. Fan is spinning but compressor does not cock AR2 in Test Chamber.	<ul style="list-style-type: none"> a. Damaged AR2. b. Damaged compressor. c. Leak in cylinder. 	<ul style="list-style-type: none"> a. Replace AR2 and attempt to cock a known serviceable AR2. a. Replace compressor (WP 0021 00). b. Replace Test Chamber.
5. Pressure gage fails to operate properly and compressor is good.	<ul style="list-style-type: none"> a. Damaged pressure gage. 	<ul style="list-style-type: none"> a. Replace Test Chamber.

TROUBLESHOOTING PROCEDURES - CONT

0015 00

INITIAL SETUP INFORMATION - CONT

TABLE 1. TROUBLESHOOTING (CONT)
TEST CHAMBER ASSEMBLY, MODEL 452

Malfunction	Probable Cause	Corrective Action
6. Altimeter pointer shows jerky motion when displaying falling altitude.	a. Vibrator not operating. b. Damaged altimeter vibrator.	a. Check electrical connection to altimeter. b. Replace altimeter (WP 0021 00).
7. Altimeter does not work.	a. Damaged altimeter.	a. Replace altimeter (WP 0021 00).

TABLE 2. TROUBLESHOOTING
ELECTRONIC TEST CHAMBER ASSEMBLY, MODEL 453

Malfunction	Probable Cause	Corrective Action
1. Unit fails to operate.	a. Power cord not plugged in. b. Blown fuse.	a. Plug power cord into 110 VAC, 50/60 Hz outlet. b. Replace fuse.
2. Fan fails to spin after repeated attempts.	a. Vacuum pump/compressor not plugged in. b. Worn or damaged vacuum pump/compressor.	a. Plug vacuum pump/compressor into control assembly (c). b. Replace vacuum pump/compressor (WP 0022 00)
3. Displays garbled or non-functional.	a. Damaged control assembly.	a. Replace control assembly (WP 0022 00).
4. Displays will not reset.	Piston rod location incorrect.	Implement reset procedure (WP 0010 00).
5. Panel indicators, controls or electric interlocks do not operate as described.	a. Electrical connector not plugged in. b. Damaged control assembly.	a. Plug electrical connector into control assembly. b. Replace control assembly (WP 0022 00).

INITIAL SETUP INFORMATION

TABLE 2. TROUBLESHOOTING
ELECTRONIC TEST CHAMBER ASSEMBLY, MODEL 453

Malfunction	Probable Cause	Corrective Action
6. Altitude chamber does not gain or hold altitude.	<ul style="list-style-type: none"> a. Severe leak in system. b. Damaged altitude chamber gasket. c. Internal filter plugged 	<ul style="list-style-type: none"> a. Finger tighten external fittings to altitude chamber and vacuum pump/compressor. b. Replace altitude chamber gasket (WP 0022 00). c. Replace control assembly (WP 0022 00)
7. Fan on vacuum pump/compressor is spinning but compressor does not cock AR2 in altitude chamber.	<ul style="list-style-type: none"> a. Damaged AR2. b. Damaged vacuum pump/compressor. 	<ul style="list-style-type: none"> a. Replace AR2 and attempt to cock a known serviceable AR2. b. Replace vacuum pump/compressor (WP 0022 00).
8. Displayed or calculated fall rate deviates from set value by more than 2 ft/sec.	<ul style="list-style-type: none"> a. Fall rate span out of adjustment. b. Damaged control assembly. 	<ul style="list-style-type: none"> a. Send unit to calibration facility (WP 0025 00). b. Replace control assembly (WP 0022 00).

END OF WORK PACKAGE

THIS PAGE INTENTIONALLY LEFT BLANK

CHAPTER 4

UNIT MAINTENANCE INSTRUCTIONS

FOR

AUTOMATIC RIPCORDER RELEASE, AR2, MODEL 451

TEST CHAMBER ASSEMBLY, AR2, MODEL 452

ELECTRONIC TEST CHAMBER ASSEMBLY, AR2, MODEL 453

THIS PAGE INTENTIONALLY LEFT BLANK

SERVICE UPON RECEIPT

AUTOMATIC RIPCORD RELEASE, MODEL 451

1. Check for shipping damage. Check for open, damaged or dented packages or evidence of dampness. Report any shipping damage on SF 365 Transportation Discrepancy Report (TDR).
2. Unpacking. The AR2 and its power cables are shipped in separate multi unit packages. Remove and count AR2 units and power cables. Compare count to shipping manifest.
3. Checking the equipment.
 - a. Check for missing components, including damaged or missing decals.

CAUTION

Move the JUMP/OFF switch between two detent positions. Do not force the switch past either detent position. This may damage internal components of the AR2 and cause malfunction.

- b. Check that JUMP/OFF switch is secure and does not bind when operated.
 - c. Check that AR2 was shipped with a storage cable and piston rod cap installed.
 - d. Check that power cables have a lanyard assembly installed.
 - e. Check that cables with detachable eyes were shipped with eyes attached. Inspect detachable eyes on power cables for looseness, distortion, or damage.
4. Report any discrepancies on SF 364 Report of Discrepancy (ROD).

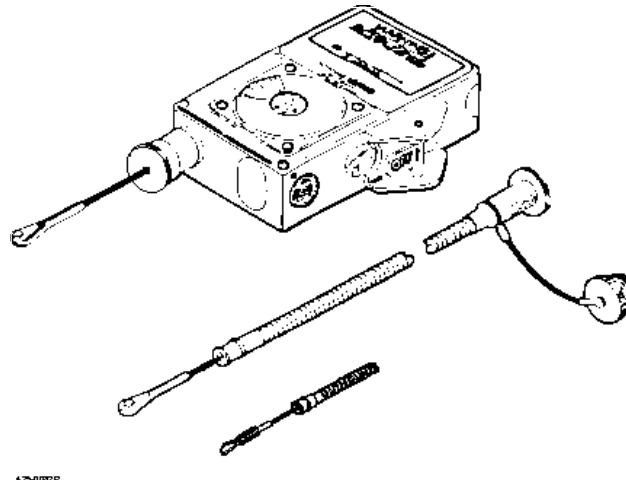

SERVICE UPON RECEIPT, TEST CHAMBER ASSEMBLY, MODEL 452

1. Check for shipping damage. Check carrying case for dents, holes, corrosion, broken carrying handles or open or damaged latches. Retain carrying case for future storage or movement. Report any shipping damage on SF 365 Transportation Discrepancy Report (TDR).

WARNING

Test chamber in carrying case weighs 70 lbs. Weight when mounting base is out of carrying case is 50 lbs: Use two persons or lifting device when moving to prevent injury to personnel.

2. Unpacking. Open test chamber carrying case cover. Lift and remove mounting base with attached components from carrying case.
3. Checking the equipment. Check for loose or missing attaching hardware or decals. Ensure that all knobs and switches are present and operate without binding. Check for broken glass on test chamber control assembly gages. Check for damage to altitude chamber, lid or gasket.
4. Report any discrepancies on SF 364 Report of Discrepancy (ROD).

SERVICE UPON RECEIPT, ELECTRONIC TEST CHAMBER ASSEMBLY, MODEL 453

1. Check for shipping damage. Check carrying case for dents, holes, corrosion, broken carrying handles or open or damaged latches. Retain carrying case for future storage or movement. Report any shipping damage on SF 365 Transportation Discrepancy Report (TDR).

WARNING

Test chamber in carrying case weighs 60 lbs. Weight when mounting case is out of the carrying case is 42 lbs. Use two persons or lifting device when moving to prevent injury to personnel.

2. Unpacking. Open test chamber carrying case cover. Lift and remove test chamber from carrying case.
3. Checking the equipment. Check for loose or missing attaching hardware or decals. Ensure that no damage has occurred to control panel or other components. Check for damage to altitude chamber, lid or gasket.

Report any discrepancies on SF 364 Report of Discrepancy (ROD)

PRELIMINARY CHECKS AND ADJUSTMENTS

0017 00

CONTROLS AND INDICATORS

Controls and indicators refer to WP 0007 for Automatic Ripcord Release, Model 451, WP 0007 for Test Chamber Assembly, Model 452, or WP0007 for Electronic Test Chamber Assembly, Model 453.

CHECKS AND ADJUSTMENTS

Perform operation under usual conditions per WP 0008 00 for Automatic Ripcord Release, Model 451, WP 0009 for Test Chamber Assembly, Model 452, or WP0010 for Electronic Test Chamber Assembly, Model 453.

THIS PAGE INTENTIONALLY LEFT BLANK

INITIAL SETUP**MAINTENANCE LEVEL**

Unit

INTRODUCTION**GENERAL**

The following PMCS tables have been provided so you can keep your equipment in good operating condition and ready for its primary mission.

Warnings and cautions appear before applicable procedures. You must observe these **WARNINGS** and **CAUTIONS** to prevent serious injury to yourself and others and to prevent your equipment from being damaged.

There are no lubrication requirements.

Item Number Column. Numbers in this column are for reference. When completing DA Form 2404 (Equipment Inspection and Maintenance Worksheet), or applicable service equivalent, include the item number for the check/service indicating a fault. Item numbers also appear in the order that you must do checks and services for the intervals listed.

Interval Column. This column tells you when you must do the procedure in the procedure column.

BEFORE procedures must be done before you operate or use the equipment for its intended mission. **DURING** procedures must be done during the time you are operating or using the equipment for its intended mission. **AFTER** procedures must be done immediately after you have operated or used the equipment.

Location, Item to Check/Service Column. This column provides the location and the item to be checked or serviced. The item location is underlined.

Procedure Column. This column gives the procedure you must do to check or service the item listed in the Check/Service column to know if the equipment is ready or available for its intended mission or for operation. You must do the procedure at the time stated in the interval column.

Not Fully Mission Capable if: Column. Information in this column tells you what faults will keep your equipment from being capable of performing its primary mission. If you do check or service procedures that show faults listed in this column, do not operate the equipment. Follow standard operating procedures for maintaining the equipment or reporting equipment failure.

Other Table Entries. Be sure to observe all special information and notes that appear in your table.

PREVENTIVE MAINTENANCE CHECKS AND SERVICES (PMCS) - CONT

0018 00

PMCS

Interval periods are defined as follows:

B-Before Operation

D-During Operation

A-After Operation

Table 1. Preventive Maintenance Checks and Services for Automatic Ripcord Release, Model 451

Item No.	Interval			Location Item to Check/Service	Procedure	Not fully Mission Capable if:
	B	D	A			
1	•			Aneroid	a. Check for aneroid leakage (WP 0008 00) b. Check that AR2 is cocked.	a. Aneroid is leaking b. AR2 is not cocked
2			•	Power Cable and Housing	If unit actuated, inspect power cable and housing (refer to WP 0019 00).	Power cable is frayed or binds. Power housing conduit has loose convolutions.

ADDITIONAL PMCS

The AR2 shall be tested and certified at each of the following times. Refer to WP 0009 00 for testing with the Model 452 Test Chamber Assembly. Refer to WP 0010 00 for testing with the Model 453 Electronic Test Chamber Assembly.

1. When the AR2 is put into service after being stored longer than 120 days.
2. At each 120-day interval while in service.
3. After 50 jumps, regardless of time interval.
4. After any jump where there is a possibility that the AR2 was damaged or malfunctioned.

The AR2 shall be taken out of service and returned to depot for overhaul after 500 cumulative actuations or 4 years, whichever comes first. Refer to Maintenance Log, WP 0008 00. Cumulative actuations include both those recorded in the Jump Log Record and those from the AR2 Maintenance Log sheets, WP 0042 00.

PREVENTIVE MAINTENANCE CHECKS AND SERVICES (PMCS)

0018 00

PMCS

Interval periods are defined as follows:

B-Before Operation

D-During Operation

A-After Operation

Table 2. Preventive Maintenance Checks and Services for Test Chamber Assembly, Model 452

Item No.	Interval			Location Item to Check/Service	Procedure	Not fully Mission Capable if:
	B	D	A			
1	•			Altimeter barometric adjustment knob	Check that altimeter barometric adjustment is set to 29.92 in Hg.	Altimeter is set to incorrect barometric pressure.
2	•			Altimeter chamber gasket	Check condition of gasket.	Gasket worn or damaged.
3		•		Vacuum pump/compressor cooling fans	Check that <u>both</u> fans are spinning. If not, cycle CLIMB/FALL/COCK switch until fans begin to spin.	Cooling fans are not spinning.

ADDITIONAL PMCS

The Model 452 Test Chamber Assembly, while in service, shall be functionally tested at 30-day intervals (refer to WP 0009 00).

The altimeter shall be tested and calibrated at 120-day intervals (refer to WP 0024 00). Calibration shall be performed by authorized calibration activity only.

PREVENTIVE MAINTENANCE CHECKS AND SERVICES (PMCS) - CONT

0018 00

PMCS - CONT

Interval periods are defined as follows:

B-Before Operation

D-During Operation

A-After Operation

Table 3. Preventive Maintenance Checks and Services for Electronic Test Chamber Assembly, Model 453

Item No.	Interval			Location Item to Check/Service	Procedure	Not fully Mission Capable if:
	B	D	A			
1	•			Tubing	Integrity of external tubing; finger tighten tubing.	Tubing damaged or connectors loose.
2	•			Electrical connectors	Check that electrical connections are secure.	Electrical connectors loose or unplugged
3	•			Altitude chamber gasket	Check condition of gasket.	Gasket worn, damaged or out of groove in chamber.
4		•		Fan on compressor not spinning	Press HOLD DOWN TO COCK switch until fan begins to spin.	Cooling fan not spinning.

ADDITIONAL PMCS

1. Perform the following functional tests every 30 days while in use.

- a. Altitude Stability Test (Refer to WP 0010 00)
- b. Fall Rate Selector Accuracy (Refer to WP 0010 00).

Perform altitude accuracy verification every 185 days (refer to WP 0025 00). Calibration shall be performed by authorized calibration activity only.

**POWER CABLE ASSEMBLY, MAIN/RESERVE
UNIT MAINTENANCE**

0019 00

THIS WORK PACKAGE COVERS:

Removal, cleaning, inspection, repair, replacement, and installation

INITIAL SETUP

TOOLS

Screwdriver, Phillips, No. 2 (WP 0041 00, Item 7)
Wrench, Adjustable, 6 inch (WP 0041 00, Item 14)
Knife (WP 0041 00, Item 1)

MATERIALS

Isopropyl Alcohol (Anhydrous) (WP 0040 00, Item 1)
Cloth, Lint Free, Cleaning (WP 0040 00, Item 3)

GENERAL

This work package contains information and instructions to keep the AR2 power cable assembly in good repair.

WARNING

Do not open or remove screws of AR2 housing. No internal maintenance is authorized. Unauthorized disassembly may cause a malfunction which may result in death of parachutist.

REMOVAL OF AR2 AND POWER CABLE ASSEMBLY

1. Ensure that the JUMP/OFF switch is OFF.

NOTE

If AR2 has not actuated, go to step 4.

2. If the AR2 has actuated, remove the AR2 and its power cable assembly from the parachute by removing tacking, two screws, nuts and clamp. These parts (hardware) are accessories attached to the parachute.

WARNING

Short power cables are fitted with detachable eyes. After cocking the AR2 mechanism, always re-inspect the detachable eye for distortion or other damage which may cause it to break in use so that parachute may not deploy which may result in death of parachutist. Discard and replace eye showing distortion or damage.

REMOVAL OF AR2 AND POWER CABLE ASSEMBLY - CONT

3. Use a screwdriver or other suitable tool, inserted through eye of power cable to form a T-handle. Secure AR2. Pull eye of power cable until the AR2 mechanism reaches the cocked position and power cable remains extended from power housing (requires approximately 70 pounds pull).
4. Unscrew power housing retainer from spring housing and remove power cable assembly by disengaging ball of power cable from piston rod. Attach storage cable and piston rod cap to AR2

INSPECTION OF POWER CABLE ASSEMBLY PRIOR TO DISSASSEMBLY

1. Shift power cable back and forth inside power housing as far as possible to expose both ends of cable.
2. Visually inspect the exposed portion of power cable for fraying. Any fraying or broken strands of wire indicate a defective power cable, which must be replaced.
3. Move power cable back and forth within power housing. A slight drag due to power cable seal is normal, but the cable should move smoothly and not bind. If there is any doubt as to the smoothness of motion, disassemble the power cable assembly and inspect all parts for wear or damage. Replace any defective parts, including, if necessary, power housing.

WARNING

The power housing (outer flexible metal casing) must be inspected for looseness between its convolutions. Looseness indicates either damage or a loss of interference fit between the outer housing and teflon liner, which maintains the housing length. Changes in housing length will affect the pulling stroke of the AR2 and could result in incomplete extraction of ripcord pins.

4. Grasp the outer flexible metal housing casing with both hands, thumbs pointing toward each other. Hold the housing firmly by pinching between thumbs and fingers. Placement of thumbs should be two to three inches apart, allowing clear visibility of the casing between thumbs.
5. Alternately push and pull the housing by applying approximately 10 pounds of force. Convolutions must not move relative to each other, but be careful not to mistake small changes in hand position caused by the pushing and pulling action for movement of the convolutions. Casing should look and feel solid, indicating no movement between convolutions.
6. Relocate the hand position and apply the procedure at four-inch to six-inch intervals over the entire length of the power housing. Verify that no movement between the casing convolutions exists. Any relative movement of the housing convolutions indicates a defective power housing, which must be replaced.

DISASSEMBLY OF POWER CABLE ASSEMBLY

1. Tap flange end of power housing on a table top to cause the cable seal retainer to protrude from the power housing. If necessary, reach behind the cable seal retainer with a small hooked tool to start it from the power housing so that it may be gripped with the fingers. Slow withdrawal of cable seal retainer will usually bring power cable seal with it. If not, use same tool to free power cable seal and remove it.
2. Pull ball of power cable through power cable seal and remove power cable from power housing.
3. If power housing or power housing retainer must be replaced, first remove small split retaining ring from flanged fitting using thin screwdriver, knife blade, or other suitable tool. Insert the tool between the two layers of the ring and carefully run the tool around the fitting to cam the ring out of its groove. Be careful not to damage or lose the retaining ring.
4. Remove the retaining ring, lanyard assembly, and power housing retainer off the small end of power housing.
5. On Reserve Power Cable Assemblies, unscrew retainer and remove detachable eye.

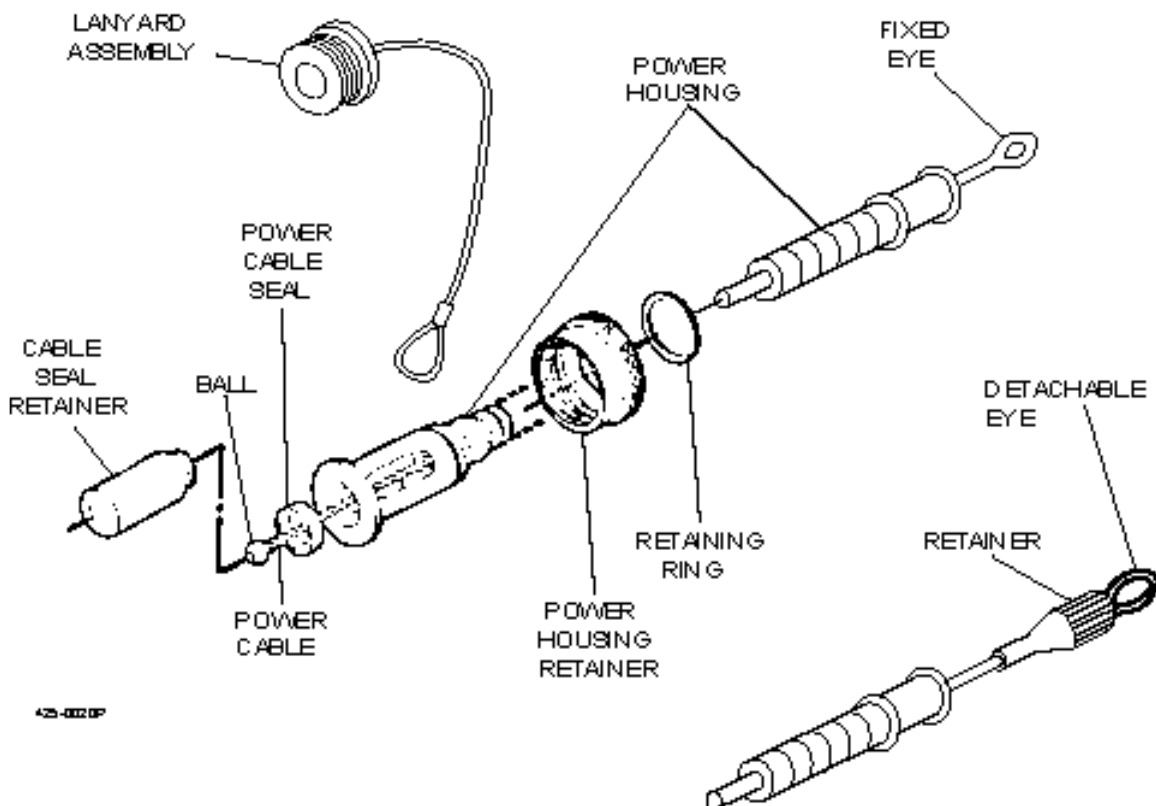

**POWER CABLE ASSEMBLY, MAIN/RESERVE
UNIT MAINTENANCE - CONT**

0019 00

CLEANING

1. Clean exterior of power housing by wiping with a clean, lint-free cloth (WP 0040 00, item 3) moistened with anhydrous isopropyl alcohol (WP 0040 00, Item 1).
2. Clean all metal parts (except power housing) by washing in anhydrous isopropyl alcohol (WP 0040 00, Item 1) and dry thoroughly.

INSPECTION

1. Visually inspect all components for wear or damage.
2. Discard worn or damaged parts.
3. Visually inspect entire power cable for fraying of cable or broken strands of wire. Discard if worn or damaged.

ASSEMBLY OF POWER CABLE ASSEMBLY

1. On Reserve Power Cable Assemblies, install legs of detachable eye into holes of cable fitting and firmly screw down retainer.
2. If removed, install power housing retainer over small end of power housing. Note orientation of threaded end of retainer (refer to the figure).
3. Install lanyard assembly over small end of power housing.
4. Reinstall split retaining ring over small end of power housing and start tail of split end into groove in flanged fitting of power housing.
5. Using knife blade or fingernail, run around retaining ring to cam it into groove in fitting.
6. Slide power cable into power housing by inserting ball of power cable into smaller end of power housing. Slide power cable completely through power housing until ball protrudes from opposite end of power housing.
7. Slip power cable seal over all of power cable and into end of power housing. Seat power cable seal fully within power housing by slowly pulling on eye end of power cable.
8. Install cable seal retainer in end of power housing and against power cable seal. Use firm thumb pressure to seat nose of cable seal retainer within recess of power cable seal.
9. If an AR2 is not immediately attached, thread plug of lanyard assembly into power housing retainer.

INSTALL POWER CABLE ASSEMBLY

1. The following instructions describe attachment of the power cable assembly to the AR2. Detailed instructions for installation of AR2 power cable assembly into parachute system are given in TM10-1670-287-23&P or service specific parachute packing manuals.

WARNING

When attaching the power cable assembly to the AR2, always verify proper engagement of ball end of power cable with piston rod of AR2 by looking through transparent plastic cable seal retainer. Cable seal retainer and power cable seal must be present to ensure correct seating of power cable ball. If ball is not engaged with piston rod, or if cable seal retainer is missing, actuation of AR2 will fail to pull ripcord pins, which may result in death of parachutist.

CAUTION

Finger tighten the power housing retainer. Do not use pliers or other tools that will overtighten power housing retainer and possibly damage retainer.

NOTE

If AR2 is to be stored, install storage cable and piston rod cap instead of power cable (Refer to preparation for storage, this work package).

2. Hook ball of power cable into recess in piston rod.
3. Slide power housing over piston rod and install power housing retainer finger tight on spring housing.
4. Verify that ball is engaged by looking through transparent cable seal retainer.
5. Verify that JUMP/OFF switch is in OFF position.

END OF WORK PACKAGE

THIS PAGE INTENTIONALLY LEFT BLANK

**AUTOMATIC RIPCORD RELEASE, AR2
JUMP/OFF SWITCH MAINTENANCE**

0020 00

THIS WORK PACKAGE COVERS:

Removal, cleaning, inspection, repair, replacement, and installation

INITIAL SETUP

TOOLS

Screwdriver, Slotted, 5/32-inch (WP 0041 00, Item 11)

MATERIALS

Isopropyl Alcohol (WP 0040 00, Item 1)

Lubricant, Antiseize (WP 0040 00, Item 2)

Cloth, Lint Free, Cleaning (WP 0040 00, Item 3)

GENERAL

This work package contains information and instructions to keep the AR2 JUMP/OFF switch in good repair.

REMOVAL AND DISASSEMBLY OF JUMP/OFF SWITCH

CAUTION

Ensure that no foreign matter enters the AR2 through power cable openings, push rod opening or screw holes.

1. If replacement is required, remove four screws (1) securing JUMP/OFF switch (2) and remove JUMP/OFF switch (2). Move JUMP/OFF switch lever back and forth to access screws (1).
2. Remove packing (3), push rod (4) and push rod spring (5) from body of unit.

NOTE

Before removing OFF and JUMP decals (6 and 7) observe where and how they are positioned.

REMOVAL AND DISASSEMBLY OF JUMP/OFF SWITCH - CONT

3. If replacement decals are required, peel off OFF decal (6) and JUMP decal (7).

NOTE

Do not remove SERVICE RECORD decal or altitude cover decal from AR2 housing.

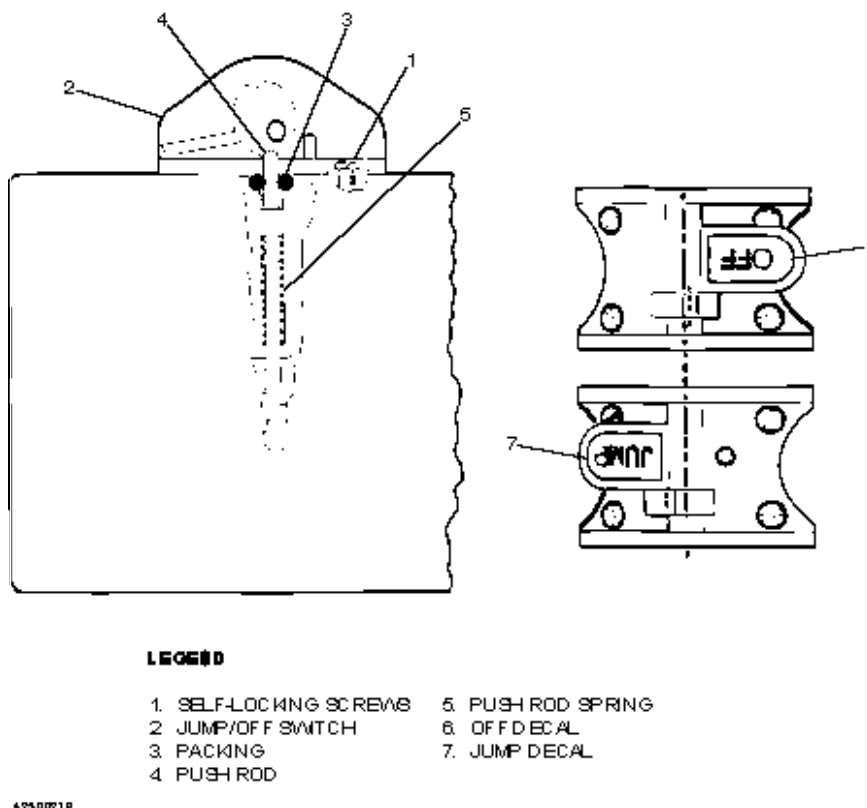

ASSEMBLY AND INSTALLATION OF JUMP/OFF SWITCH

WARNING

Make sure the jump and off decals are replaced on the correct sides of the switch lever. Incorrectly placed decals will give a false indication of AR2 condition and may result in death if the AR2 is used in a jump.

**AUTOMATIC RIPCORD RELEASE, AR2
JUMP/OFF SWITCH MAINTENANCE**

0020 00

1. Use lint-free cleaning cloth (WP 0040 00, Item 3) moistened with anhydrous isopropyl alcohol (WP 0040 00, Item 1) to clean areas where decals were mounted. Install new OFF decal (6) and JUMP decal (7) by peeling protective back from new decals and placing new decals in position. Press each new decal **firmly** in place.

CAUTION

When replacing the JUMP/OFF switch, always install the new push rod spring, push rod, and packing that are included in the switch kit. **Never use an old push rod spring, push rod, or packing with a new switch.**

2. If removed, lubricate packing (3) with anti-seize lubricant (WP 0040 00, Item 2) and install new push rod spring, (5) push rod (4) and packing (3).

CAUTION

Use care not to damage packing when installing JUMP/OFF switch.

3. Position and install new JUMP/OFF switch. Move JUMP/OFF switch lever back and forth to access screw holes.
4. Install and tighten self-locking screws.
5. Set the JUMP/OFF switch to OFF.
6. Test AR2 in accordance with procedures in WP 0009 00 or WP 0010 00 to be sure it functions correctly.

END OF WORK PACKAGE

THIS PAGE INTENTIONALLY LEFT BLANK

**TEST CHAMBER ASSEMBLY, MODEL 452
UNIT MAINTENANCE**

0021 00

THIS WORK PACKAGE COVERS:

Disassembly, calibration, cleaning, inspection, and reassembly.

INITIAL SETUP

TOOLS

Putty Knife (WP 0041 00, Item 6)
Wrench, Open End, 5/8-inch (WP 0041 00, Item 15)
Wrench, Open End, 11/16-inch (WP 0041 00, Item 16)
Nutdriver, 3/8-inch (WP 0041 00, Item 5)
Screwdriver, Slotted, 1/4-inch (WP 0041 00, Item 12)

MATERIALS

Isopropyl Alcohol (Anhydrous) (WP 0040 00, Item 1)
Cloth, Lint Free, Cleaning (WP 0040 00, Item 3)
Tags (ID) (WP 0040 00, Item 4)

GENERAL

This work package contains information and instructions to keep the Test Chamber Assembly, Model 452 in good repair.

WARNING

Mounting base with attached components weighs 50 lbs, weight when mounting base is installed in carrying case is 70 lbs. Use two persons when moving or lifting to avoid injury to personnel.

CAUTION

Do not lift test chamber and base by grasping altitude chamber. Grasp altitude regulator in right hand and head of compressor in left hand to lift test chamber from carrying case.

INSPECTION PRIOR TO DISASSEMBLY

1. Open carrying case (2) and lift out mounting base (29) with attached components. Place on a work bench.
2. Visually inspect all components for wear or damage.
3. Ensure that altitude chamber gasket (30) is not damaged.
4. Note all failures during initial adjustments before use (WP 0009 00).

INSPECTION PRIOR TO DISASSEMBLY - CONT**NOTE**

If test chamber will not maintain high altitudes with CLIMB/FALL/COCK switch in CLIMB position, there is a leak in the pneumatic system. Check all compression nuts for tightness with the fingers. **DO NOT USE WRENCHES.** Carefully examine gasket for flaws or damage and replace, if necessary. If the chamber still will not maintain altitude, send the chamber back to depot for repair.

DISASSEMBLY**NOTE**

When disassembling the test chamber, use care to prevent scratching the altitude chamber. Be careful not to damage mating surface of altitude chamber when removing damaged gasket.

1. Remove damaged altitude chamber gasket (30) by carefully pulling gasket away from altitude chamber. A putty knife or similar tool may be used to aid in gasket removal.
2. If replacement is required, peel off identification decal (1) from carrying case (2), and from control housing (6), WARNING decal (5), FUNCTIONS decal (7), and CONNECTIONS decal (15). Retain identification decal (1).
3. If replacement of air compressor (13), vacuum pump (14) or altimeter (26) is necessary, remove four screws (18) holding the housing panel (19) to the control housing (6). Connection strip (17) mounted inside control housing (6) contains all electrical connections from the input power and various components. The connections are identified on connections decal (15) found inside housing panel (19)
4. Unfasten and detach electrical connector (16) from altimeter (26). Unscrew compression nut (21) and disconnect tubing (22) from elbow (20).
5. Remove three screws (27) and lift altimeter (26) from control housing (6).

NOTE

Observe orientation of elbow (20) to aid in assembly.

6. If replacement altimeter (26) has no elbow (20) attached, it will be necessary to transfer elbow from the unit being removed to the replacement.

CAUTION

No sealant is used with elbow (20). An o-ring packing (23), located under back-up washer (24) and lock nut (25) performs this function. Make sure not to lose or damage this packing.

TEST CHAMBER ASSEMBLY, MODEL 452
UNIT MAINTENANCE

0021 00

DISASSEMBLY

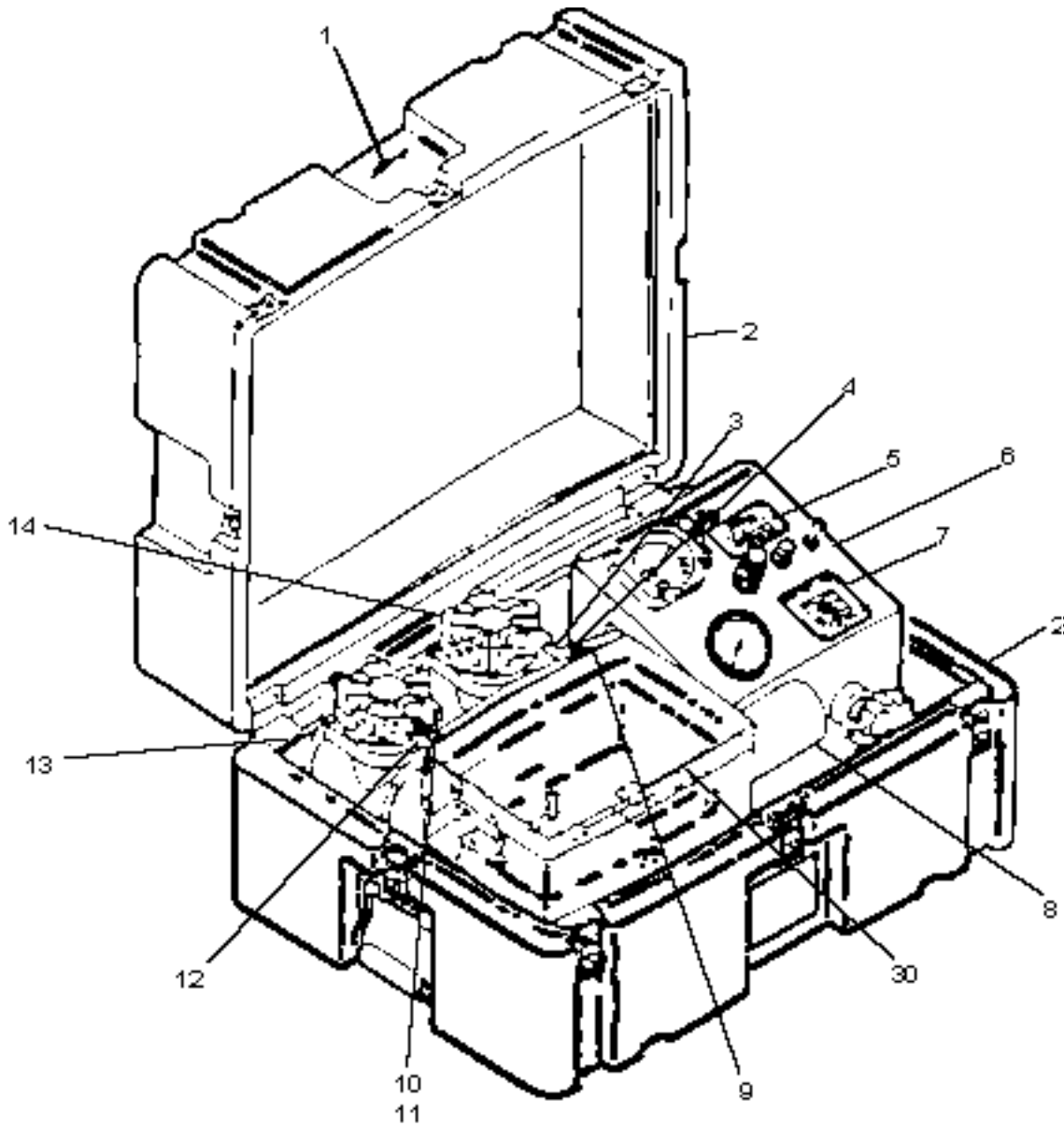

TEST CHAMBER ASSEMBLY, MODEL 452
UNIT MAINTENANCE - CONT

0021 00

DISASSEMBLY - CONT

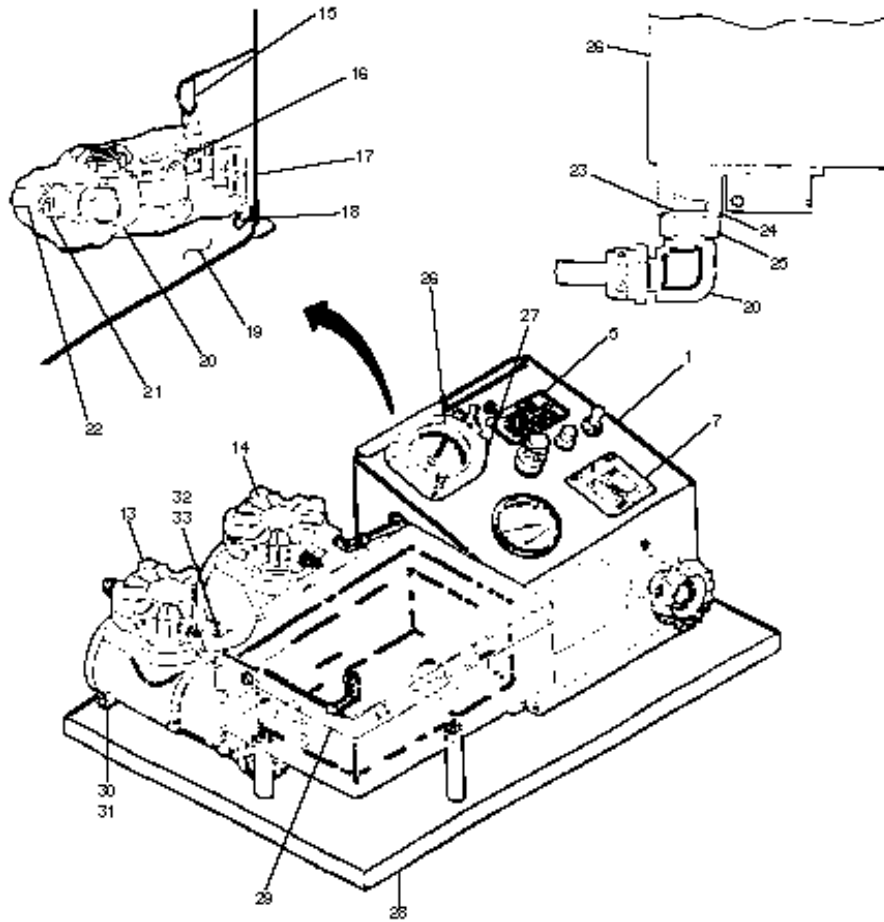

LEGEND

- | | |
|---------------------------|-----------------------------|
| 1. Identification Decal | 18. Screws |
| 2. Carrying Case | 19. Housing Panel |
| 3. Elbow | 20. Elbow |
| 4. Compression Nut | 21. Compression Nut |
| 5. Warning Decal | 22. Tubing |
| 6. Control Housing | 23. Packing |
| 7. Altitude Control Decal | 24. Backup Washer |
| 8. Air Cylinder | 25. Lock Nut |
| 9. Tubing | 26. Altimeter |
| 10. Tubing | 27. Screws |
| 11. Compression Nut | 28. Base |
| 12. Elbow | 29. Altitude Chamber Gasket |
| 13. Air Compressor | 30. Screws |
| 14. Vacuum Pump | 31. Washers |
| 15. Connections Decal | 32. Screws |
| 16. Electrical Connector | 33. Washers |
| 17. Connection Strip | |

**TEST CHAMBER ASSEMBLY, MODEL 452
UNIT MAINTENANCE**

0021 00

DISASSEMBLY

7. Hold elbow (20) stationary using a 5/8-in. backup wrench, and loosen lock nut (25) approximately one turn using a 11/16-in. wrench. Elbow (20) may then be removed by hand.
8. Tag and disconnect three electrical leads to air compressor (13). Refer to connections decal (15) inside of housing panel (6). Unscrew compression nut (11) and disconnect tubing (10) from elbow (12).

NOTE

Observe routing of electrical leads from air compressor (13) to aid in assembly.

9. Remove three screws (31), washers (32), and compressor (13).
10. Tag and disconnect three electrical leads to vacuum pump (14). Refer to connections decal (15) inside of housing panel (19). Unscrew compression nut (4) and disconnect tubing (9) from elbow (3).

NOTE

Observe routing of electrical leads from vacuum pump (14) to aid in assembly.

11. Remove three screws (33), washers (34), and vacuum pump (14).

ALTIMETER CALIBRATION

Refer to direct support maintenance (WP 0024 00).

CLEANING

1. Clean exterior of air compressor (13), vacuum pump (14), and air cylinder (8) with isopropyl alcohol (anhydrous). Air dry all parts thoroughly.

INSPECTION

1. Visually inspect all components for wear or damage.
2. Discard worn or damaged parts.

ASSEMBLY

1. Install replacement vacuum pump (14) using three washers (34) and screws (33).
2. Connect tubing (9) to elbow (3) on vacuum pump (14) and secure with compression nut (4)(finger tight).
3. Route and reconnect electrical leads to vacuum pump (14) as identified at disassembly and remove tags.
4. Install replacement air compressor (13) using three washers (32) and screws (31).
5. Connect tubing (10) to elbow (12) on air compressor (13) and secure with compression nut (11)(finger tight).
6. Route and reconnect electrical leads to air compressor (13) as identified at disassembly and remove tags.
7. Use lint-free cleaning cloth and isopropyl alcohol (anhydrous) to clean areas where decals were mounted. Install new identification decal (1), making sure to transfer serial number identification of test chamber, WARNING decal (5), CONNECTIONS decal (15), and FUNCTIONS decal (7) by peeling protective back from new decals and pressing new decals firmly in position.
8. Peel protective backing off the right end (as it would be installed on the altitude chamber) of the gasket (30). Carefully align gasket and gently press in place. Continue to peel off protective backing as the gasket is installed. Use care not to develop any wrinkles in the gasket (30) or adhesive since they may cause a leak.
9. If necessary, install elbow (20) in replacement altimeter (26). Lubricate O-ring packing (23) sparingly using MIL-G-27617 lubricant. Turn elbow (20) into the threaded opening (boss) of altimeter (26) by hand until back-up washer (24) contacts the face of the boss. Position elbow (20) by backing it out (NOT MORE THAN ONE TURN COUNTERCLOCKWISE) until it is oriented correctly as observed at disassembly. Hold elbow (20) stationary, using a 5/8-in. back-up wrench, and tighten lock nut (25) with a 11/16-in. wrench until back-up washer (24) is pressed against the face of the boss of replacement altimeter (26). DO NOT OVERTIGHTEN. Joint is sufficiently tight if elbow (20) cannot be rotated with fingers.

**TEST CHAMBER ASSEMBLY, MODEL 452
UNIT MAINTENANCE**

0021 00

ASSEMBLY

10. Install replacement altimeter (26) into control housing (6) and secure with three screws (27).

CAUTION

Compression nuts used on pneumatic tube connections to air compressor (13) , vacuum pump (14), altimeter (26) and other components, such as the altitude chamber, are to be finger-tightened only. Do not use wrenches; overtightening will not give an improved seal but will hasten the splitting of compression sleeves and pneumatic tubes.

11. Connect tubing (22) to elbow (20) using compression nut (21). Attach and fasten electrical connector (16) to altimeter (26). Take care to correctly align connector (16) with the mating receptacle on altimeter (26) when assembling these parts.
12. Reassemble housing panel (19) to control housing (6) and secure with four screws (18).
13. Plug power cord into 110 VAC outlet.
14. Switch test chamber on.
15. Position CLIMB/FALL/COCK switch to CLIMB.
16. Turn altitude control regulator knob counterclockwise until altitude shown on altimeter reaches 35,000 feet.
17. Position CLIMB/FALL/COCK switch to FALL and wait until altitude falls below 25,000 feet; press and hold RAPID FALL DUMP switch until chamber reaches ground elevation.
18. Open carrying case (2) and carefully lower mounting base (29) with attached components into carrying case (2). Close and secure carrying case.

END OF WORK PACKAGE

THIS PAGE INTENTIONALLY LEFT BLANK

**ELECTRONIC TEST CHAMBER ASSEMBLY, MODEL 453
UNIT MAINTENANCE**

0022 00

THIS WORK PACKAGE COVERS:

Disassembly, cleaning, inspection assembly, calibration and adjustment.

INITIAL SETUP

TOOLS

Nutdriver, 3/8-inch (WP 0041 00, Item 5)
Screwdriver, Phillips No. 2 X 7-inch (WP 0041 00, Item 8)
Screwdriver, Phillips No. 3 (WP 0041 00, Item 9)
Screwdriver, Slotted, 3/32-inch (WP 0041 00, Item 10)

MATERIALS

Isopropyl Alcohol (Anhydrous) (WP 0040 00, Item 1)
Cloth, Lint Free, Cleaning (WP 0040 00, Item 3)

GENERAL

This work package contains information and instructions to keep the Electronic Test Chamber Assembly, Model 453 in good repair.

WARNING

Mounting base with attached components weighs 42 lbs. Weight when mounting base is installed in case is 60 lbs. Use two persons or lifting device when moving or lifting to prevent injury to personnel.

CAUTION

Do not lift mounting base with attached components by grasping altitude chamber. Grasp lifting handle on control assembly in right hand and head of compressor in left hand to lift mounting base with attached components.

INSPECTION PRIOR TO DISASSEMBLY

1. Open carrying case and lift out mounting base with attached components. Place mounting base on work bench.
2. Visually inspect all components for wear or damage.
3. Ensure that altitude chamber gasket is not damaged or depressed in any way.
4. Visually check all tubes for damage.
5. Note all failures during initial adjustments before use (WP 0010 00).

DISASSEMBLY**NOTE**

When disassembling the test chamber, use care to prevent scratching the altitude chamber or lid. Be careful not to damage mating surfaces of altitude chamber when removing damaged gasket.

1. Remove altitude chamber gasket by carefully pulling gasket from groove in altitude chamber as shown.
2. If required, peel off two test chamber identification decals (1) (one located on carrying case and one on the mounting base (9) and control assembly decal (5)(refer to decals and instruction plates, WP 0010 00). Retain decals with their serial numbers.
3. Remove vacuum pump/compressor (4) as follows:
 - a. Disconnect vacuum pump/compressor electrical plug from control assembly vacuum pump connector (11). Disconnect tubing.
 - b. Unscrew compression nuts (13, 15) holding tubing to vacuum pump/compressor. Disconnect tubing.
 - c. From underside of mounting base (9) remove four screws (16) and washers (17) securing vacuum pump/compressor (4) to mounting base; remove vacuum/compressor.
4. Remove control assembly (3) as follows:
 - a. Disconnect vacuum pump/compressor electrical plug from vacuum pump/connector (11) on control assembly.
 - b. Disconnect altitude chamber electrical connector (12) from control assembly.
 - c. Unscrew compression nuts holding tubing from ALT CHMBR port, AIR CYL port, AIR COMP port, and VAC PUMP port.
 - d. Remove four screws (14) securing control assembly to mounting base; remove control assembly.

ELECTRONIC TEST CHAMBER ASSEMBLY, MODEL 453
UNIT MAINTENANCE

0022 00

DISASSEMBLY

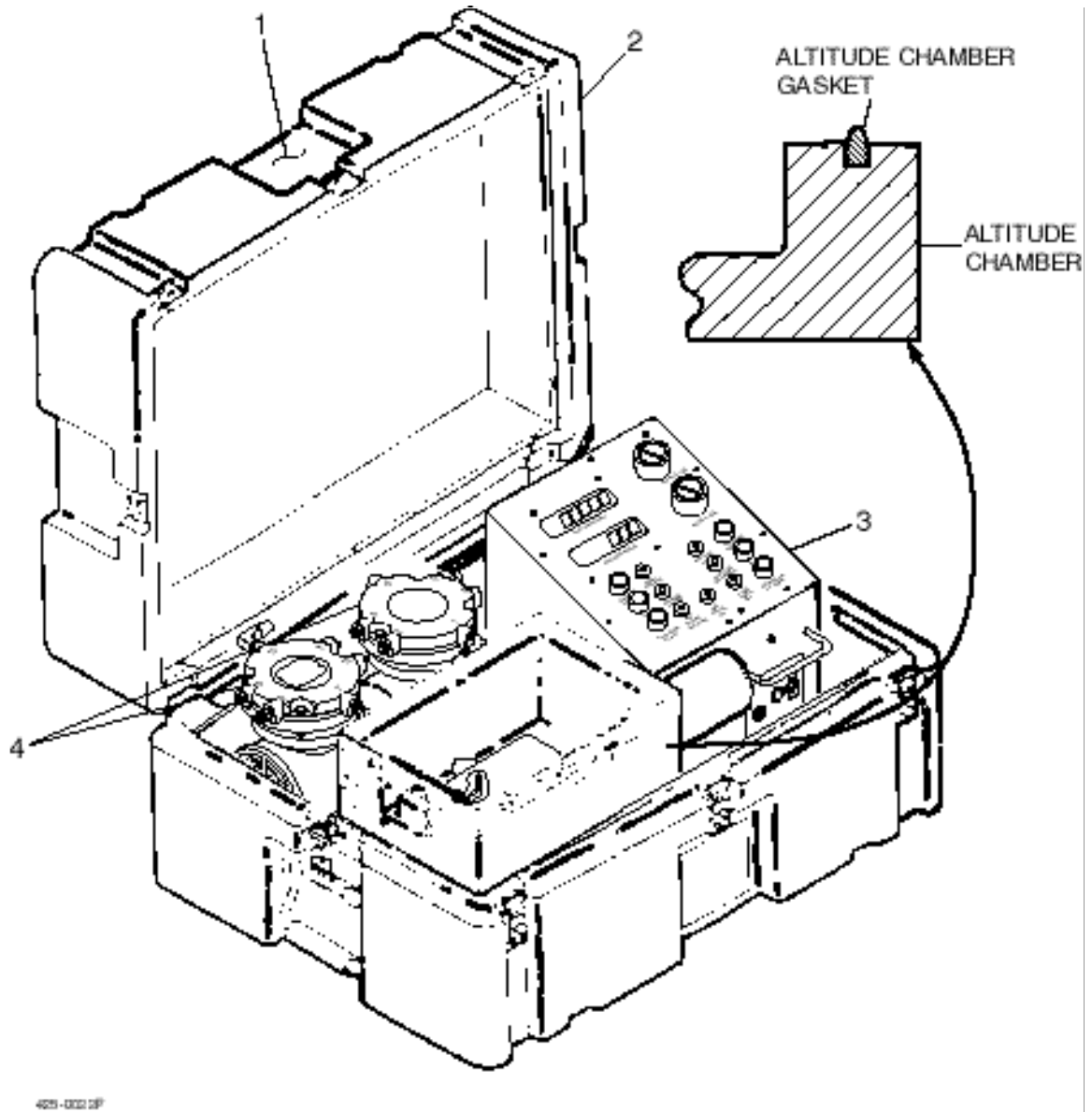

DISASSEMBLY - CONT

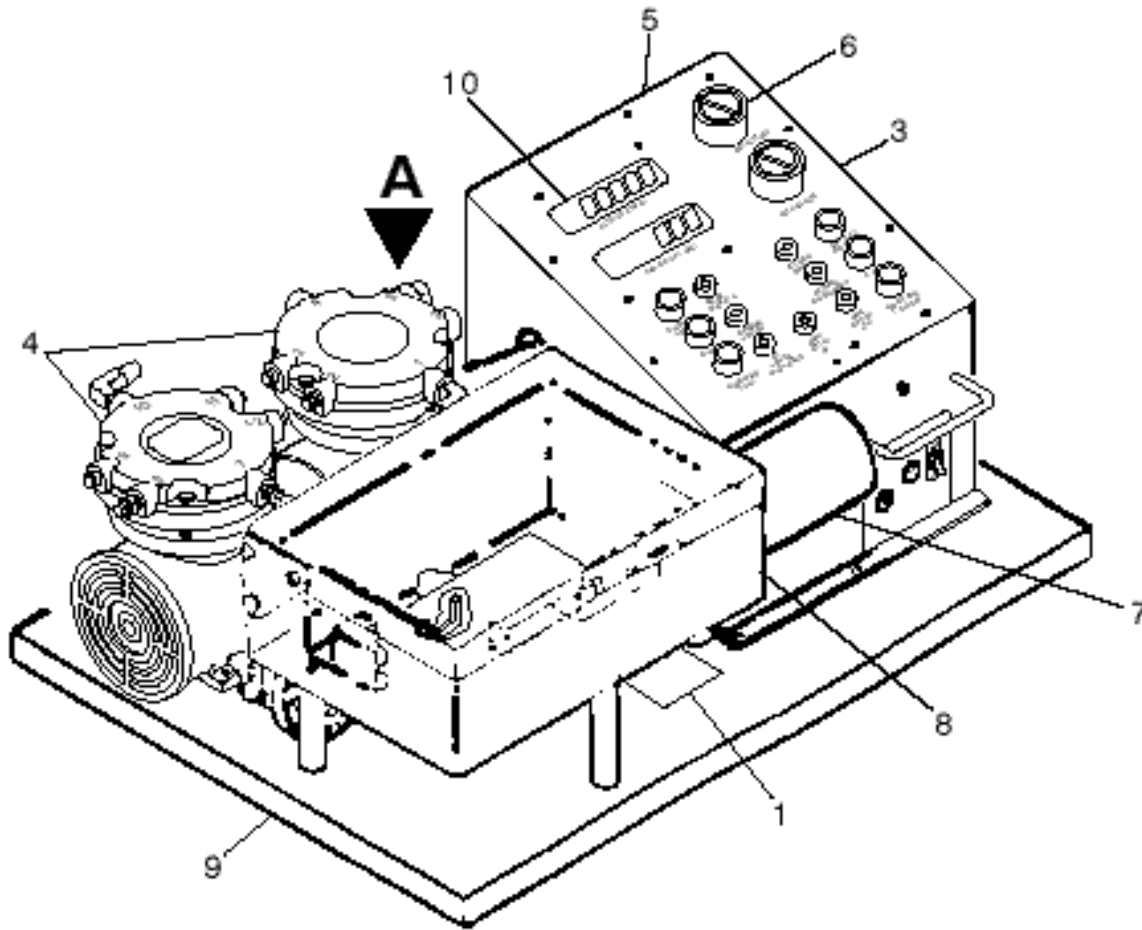

453-026 9P

**ELECTRONIC TEST CHAMBER ASSEMBLY, MODEL 453
UNIT MAINTENANCE**

0022 00

DISASSEMBLY

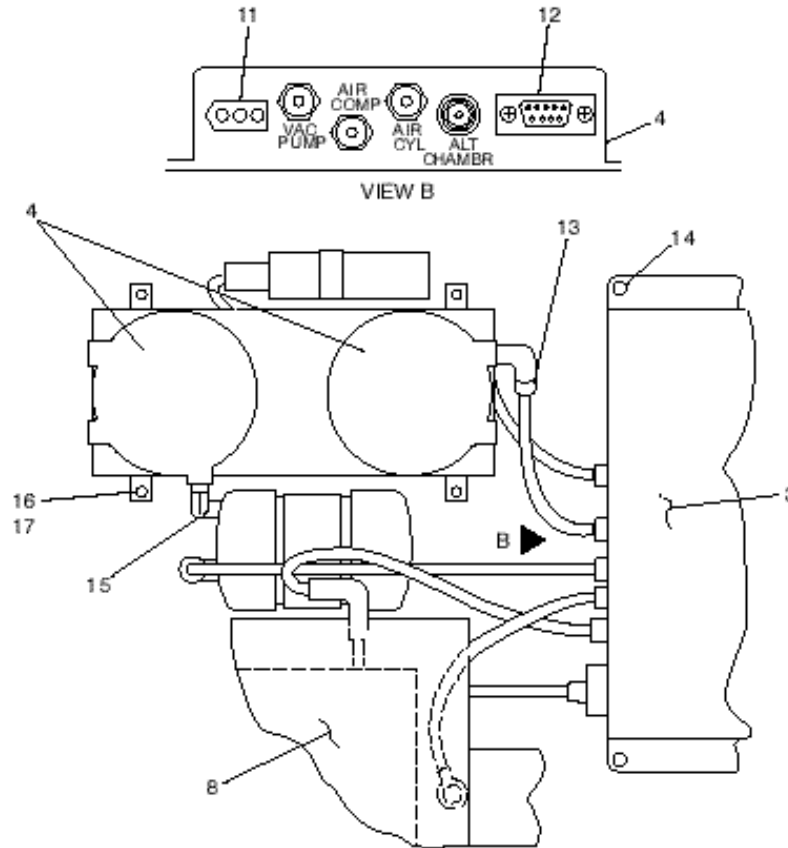

LEGEND

- | | |
|---|---|
| <ul style="list-style-type: none"> 1. ELECTRONIC TEST CHAMBER ASSY,
AR2 MODEL 453-001 DECAL (2 REQUIRED) 2. CARRYING CASE 3. CONTROL ASSEMBLY 4. VAC PUMP/AIR COMPRESSOR 5. CONTROL ASSEMBLY, PART NO. 453-100 DECAL 6. SET ALTITUDE CONTROL 7. AIR CYLINDER 8. ALTITUDE CHAMBER 9. MOUNTING BASE 10. ALTITUDE DISPLAY (FT MSL) | <ul style="list-style-type: none"> 11. VAC PUMP/COMPRESSOR CONNECTOR 12. ALTITUDE CHAMBER CONNECTOR 13. COMPRESSION NUT 14. SCREWS (4 REQUIRED) 15. COMPRESSION NUT 16. SCREWS (4 REQUIRED) 17. WASHERS (4 REQUIRED) |
|---|---|

425-001P

View A

CLEANING

1. Clean exterior of vacuum pump/compressor, control assembly, and air cylinder using isopropyl alcohol (anhydrous). Air dry all parts.

INSPECTION

1. Visually inspect all components for wear or damage.
2. Discard worn or damaged parts.

ASSEMBLY

1. Install control assembly (3) as follows:
 - a. Position control assembly (3) on mounting base (9), secure with four screws (14).

CAUTION

Compression nuts used on pneumatic tubing are to be finger-tightened only. Do not use wrenches; overtightening will not give an improved seal but will hasten the splitting of compression sleeves and pneumatic tubing.

- b. Attach tubing to VAC PUMP port, AIR COMP port, AIR CYL port and ALT CHMBR port using compression nuts finger tight.
- c. Attach altitude chamber electrical plug to altitude electrical connector (12) on control assembly (3).
- d. Attach vacuum pump/compressor electrical plug to VAC pump connector (11) on control assembly (3).

ASSEMBLY

2. Install vacuum pump/compressor (4) as follows:
 - a. Position vacuum pump/compressor (4) on mounting base (9); secure with four screws (16) and washers (17) from underside of mounting base (9).
 - b. Connect electrical cable from vacuum pump/compressor (4) to connector (11) on control assembly. Attach vacuum pump/compressor electrical plug to VAC pump connector (11) on control assembly (3).

CAUTION

Compression nuts used on pneumatic tubing are to be finger-tightened only. Do not use wrenches; over tightening will not give an improved seal but will hasten the splitting of compression sleeves and pneumatic tubing.

- c. Connect tubing to vacuum pump/compressor (4) using compression nuts (13 and 15) finger tight.
3. Use lint-free cleaning cloth and isopropyl alcohol (anhydrous) to clean areas where decals were mounted. Peel protective back and install new decals as follows, making sure to transfer serial number identification:
 - a. Control Assembly decal (located on the back of the control assembly [3]).
 - b. Two identification decals; one on the mounting base of the test chamber (9); the other on the carrying case (2).
4. Install new altitude chamber gasket in groove in altitude chamber (refer to figure). Be sure tension in gasket is equalized around its entire length.
5. Conduct Altitude Stability Test at 35,000 feet (WP 0010 00)
6. Open carrying case (2) and carefully lower mounting base (9) with attached components into carrying case (2). Close and secure carrying case.

CALIBRATION AND ADJUSTMENT

Refer to direct support maintenance (WP 0025 00)

END OF WORK PACKAGE

THIS PAGE INTENTIONALLY LEFT BLANK

AUTOMATIC RIPCORD RELEASE, MODEL 451, PREPARATION FOR STORAGE OR SHIPMENT USING MODEL 452 TEST CHAMBER ASSEMBLY

PREPARATION FOR STORAGE

WARNING

Do not transport or store AR2 without piston rod cap, storage cable or power cable attached. External forces or impacts applied to the piston rod may cause unit to malfunction. Any unit subjected to external forces or impact must be tested and, if necessary, removed from service.

NOTE

Make sure the AR2 is cocked, and the JUMP/OFF switch is set to OFF.

1. Pass ball end of storage cable (3) through piston rod cap (5) and then engage recess of piston rod. Attach piston rod cap (5) to spring housing (6) of AR2. Pull eye end of storage cable (3) to verify correct engagement.
2. Open lid of altitude chamber (7) and if necessary, remove cocking support (9).
3. Move air cylinder rod (4) as far to the right as it will go, approximately 1 inch.

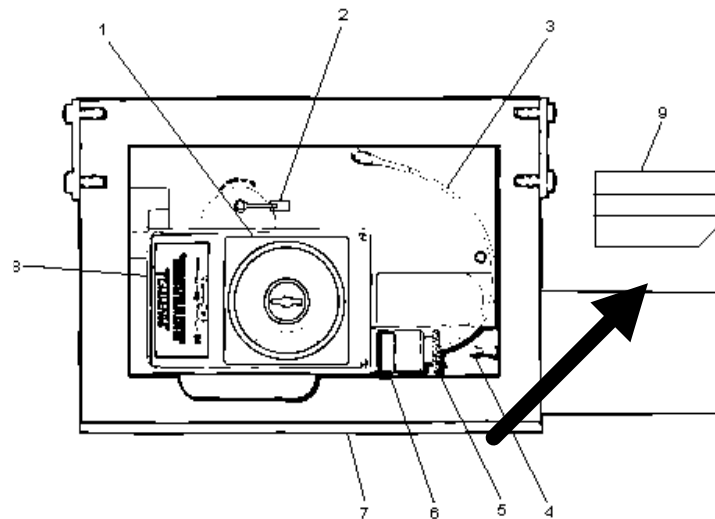

LEGEND

- | | |
|---------------------|---------------------|
| 1. ALTITUDE DIAL | 5. PISTON ROD CAP |
| 2. SWITCH LEVER | 6. SPRING HOUSING |
| 3. STORAGE CABLE | 7. ALTITUDE CHAMBER |
| 4. AIR CYLINDER ROD | 8. AR2 |
| | 9. COCKING SUPPORT |

425-0023P

AUTOMATIC RIPCORD RELEASE, MODEL 451, PREPARATION FOR STORAGE OR SHIPMENT USING MODEL 452 TEST CHAMBER ASSEMBLY - CONT

- 4 Set AR2 altitude dial (1) 1,000 feet above local MSL altitude.
- 5 Place AR2 in altitude chamber as shown.
- 6 Carefully close altitude chamber lid (7).
7. Set test chamber ON/OFF switch lever (2) to ON and CLIMB/FALL/COCK switch to CLIMB. Raise altitude to approximately 2,500 feet above the altitude set on AR2 dial.
8. Move switch lever so that JUMP/OFF switch is set to JUMP; move the CLIMB/FALL/COCK switch to FALL, depress and hold the RAPID FALL dump switch, and allow the AR2 to actuate. Observe that storage cable is drawn partially into the AR2.
9. Position JUMP/OFF switch to OFF.
10. If necessary, increase pressure in altitude chamber to ambient by holding down on RAPID FALL dump switch.
11. Switch test chamber ON/OFF switch to OFF.
12. Open lid of altitude chamber and remove AR2 with piston rod cap and storage cable attached. Verify that storage cable is correctly attached by pulling on eye end.

STORAGE

AR2 units should be shelf stored in a clean dry area and protected from accumulation of dirt.

SHIPMENT**WARNING**

Do not transport or store AR2 without piston rod cap storage cable or power cable attached. External forces or impacts applied to the piston rod may cause unit to malfunction. Any unit subjected to external forces or impact must be tested and, if necessary, removed from service.

With AR2 storage cable and piston rod cap installed, ensure that the AR2 JUMP/OFF switch is OFF. Protect AR2 with bubble pack and package using standard packing materials

AUTOMATIC RIPCORD RELEASE, MODEL 451, PREPARATION FOR STORAGE OR SHIPMENT USING MODEL 453 ELECTRONIC TEST CHAMBER ASSEMBLY**PREPARATION FOR STORAGE****WARNING**

Do not transport or store AR2 without piston rod cap storage cable or power cable attached. External forces or impacts applied to the piston rod may cause unit to malfunction. Any unit subjected to external forces or impact must be tested and, if necessary, removed from service.

NOTE

Make sure the AR2 is cocked, and the JUMP/OFF switch is set to OFF.

1. Pass ball end of storage cable (3) through piston rod cap (5) and then engage recess of piston rod. Attach piston rod cap (5) to spring housing (6) of AR2. Pull eye end of storage cable (3) to verify correct engagement.
2. Open lid of altitude chamber (7) and if necessary remove cocking support (9) (refer to illustration on page 00-1).
3. Move air cylinder rod (4) as far to the right as it will go, approximately 1 inch.
4. Set AR2 altitude dial (1) to 1,000 feet above local MSL altitude.
5. Place AR2 in altitude chamber as shown.
6. Carefully close altitude chamber lid (7).
7. Set test chamber ON/OFF switch to ON.
8. Press and hold HOLD DOWN TO SET switch; use SET ALTITUDE control to set altitude to 2500 feet above the altitude set on AR2 dial.
9. Ensure DUMP circuit is disengaged.
10. Press GO TO ALT AND DWELL switch.

AUTOMATIC RIPCORD RELEASE, MODEL 451, PREPARATION FOR STORAGE OR SHIPMENT USING MODEL 453 ELECTRONIC TEST CHAMBER ASSEMBLY - CONT

11. Use altitude chamber JUMP switch lever to set AR2 JUMP/OFF switch to JUMP.
12. Press DUMP switch and allow AR2 to actuate. Observe that storage cable is drawn partially into the AR2.
13. Set JUMP/OFF switch to OFF.
14. Set test chamber ON/OFF switch to OFF.
15. Open altitude chamber lid and remove AR2 with piston rod cap and storage cable attached. Verify that storage cable is correctly attached by pulling on eye end.

STORAGE

AR2 units shall be shelf stored in clean, dry area and protected from accumulation of dirt.

SHIPMENT**WARNING**

Do not transport or store AR2 without piston rod cap, storage cable, or power cable attached. External forces or impacts applied to the piston rod may cause unit to malfunction. Any unit subjected to external forces or impact must be tested and, if necessary, removed from service.

With AR2 storage cable and piston rod cap installed, ensure that the AR2 JUMP/OFF switch is OFF. Protect AR2 with bubble pack and package using standard packing materials.

TEST CHAMBER ASSEMBLY, MODEL 452, PREPARATION FOR STORAGE OR SHIPMENT

1. With AR2 removed from altitude chamber, verify that altitude inside altitude chamber is at ground level.
2. Verify that cocking support is inside the altitude chamber.
3. Close altitude chamber lid.
4. Disconnect power cord from 120 VAC and coil power cord under altitude chamber.

WARNING

Mounting base with attached components weighs 50 lbs. Weight when mounting base is installed in carrying case is 70 lbs. Use two persons or lifting device to prevent injury to personnel

5. Open carrying case (2) and carefully lower the mounting base (29) (with attached components) into the carrying case (2). Close and latch carrying case lid.
6. Verify that correct serial number and mfg date are shown on the carrying case identification decal (WP 0009 00).

STORAGE

Store unit in carrying case in a clean, dry area.

SHIPMENT

Ship unit in carrying case.

ELECTRONIC TEST CHAMBER ASSEMBLY, MODEL 453, PREPARATION FOR STORAGE OR SHIPMENT

1. With AR2 removed from altitude chamber, verify that altitude inside altitude chamber is at ground level.
2. Verify that cocking support is inside the altitude chamber.
3. Close altitude chamber lid.
4. Switch test chamber ON/OFF switch to OFF.
5. Disconnect power cord from 110 VAC power source and coil power cord under altitude chamber.

ELECTRONIC TEST CHAMBER ASSEMBLY, MODEL 453, PREPARATION FOR STORAGE OR SHIPMENT

WARNING

Mounting base with attached components weighs 42 lbs. Weight when mounting base is installed in carrying case is 60 lbs. Use two persons or lifting device to prevent injury to personnel. When lifting mounting base with attached components, use lifting handle and head of compressor

6. Open carrying case (2) and carefully lower the mounting base (9) (with attached components) into the carrying case (2). Close and latch carrying case lid.
7. Verify that correct serial number and mfg date are shown on the carrying case identification decal (WP 0010 00).

STORAGE

Store unit in carrying case in a clean, dry area.

SHIPMENT

Ship unit in carrying case.

END OF WORK PACKAGE

CHAPTER 5

**DIRECT SUPPORT MAINTENANCE INSTRUCTIONS
FOR
TEST CHAMBER ASSEMBLY, AR2, MODEL 452
ELECTRONIC TEST CHAMBER ASSEMBLY, AR2, MODEL 453**

THIS PAGE INTENTIONALLY LEFT BLANK

TEST CHAMBER ASSEMBLY, MODEL 452
DIRECT SUPPORT MAINTENANCE

0024 00

CALIBRATION

WARNING

Calibration of the AAU-31/A aviation altimeter may be done only by an authorized calibration laboratory or repair facility with proper altitude-measuring standard instrument.

For AAU-31/A aviation altimeter calibration procedures, refer to the applicable technical documentation covering altimeters.

THIS PAGE INTENTIONALLY LEFT BLANK

CALIBRATION AND ADJUSTMENT

WARNING

Calibration of and adjustment to the control assembly may be made only by an authorized calibration laboratory or repair facility with proper altitude-measuring standard instrument.

NOTE

If the control assembly cannot be brought into tolerance, it is defective and must be replaced.

ALTITUDE ACCURACY VERIFICATION

NOTE

Standard instrument used to verify altitude accuracy shall have a verified accuracy within 0.01 % full scale.

1. Position test chamber assembly near 110 VAC power outlet and a standard instrument.
2. Control ambient temperature to $68^{\circ} \pm 9^{\circ}\text{F}$ ($20^{\circ} \pm 5^{\circ}\text{C}$).
3. Use calibration adapter to connect calibration port on control assembly with standard instrument. A 1/8-in. male connector is provided with the calibration adapter to connect it to standard instrument.
4. Connect test chamber assembly to 110 VAC, 50/60 Hz power source.
5. Turn on both instruments and allow them to warm up for 30 minutes minimum.
6. Use SET ALTITUDE CONTROL on control assembly so that standard instrument reads within ± 5 feet of the first value in Table 1. If calibration facility is at high altitude. It may be necessary to clamp the lid of the altitude chamber to effect a seal (refer to WP 0012 00).

ALTITUDE ACCURACY VERIFICATION - CONT

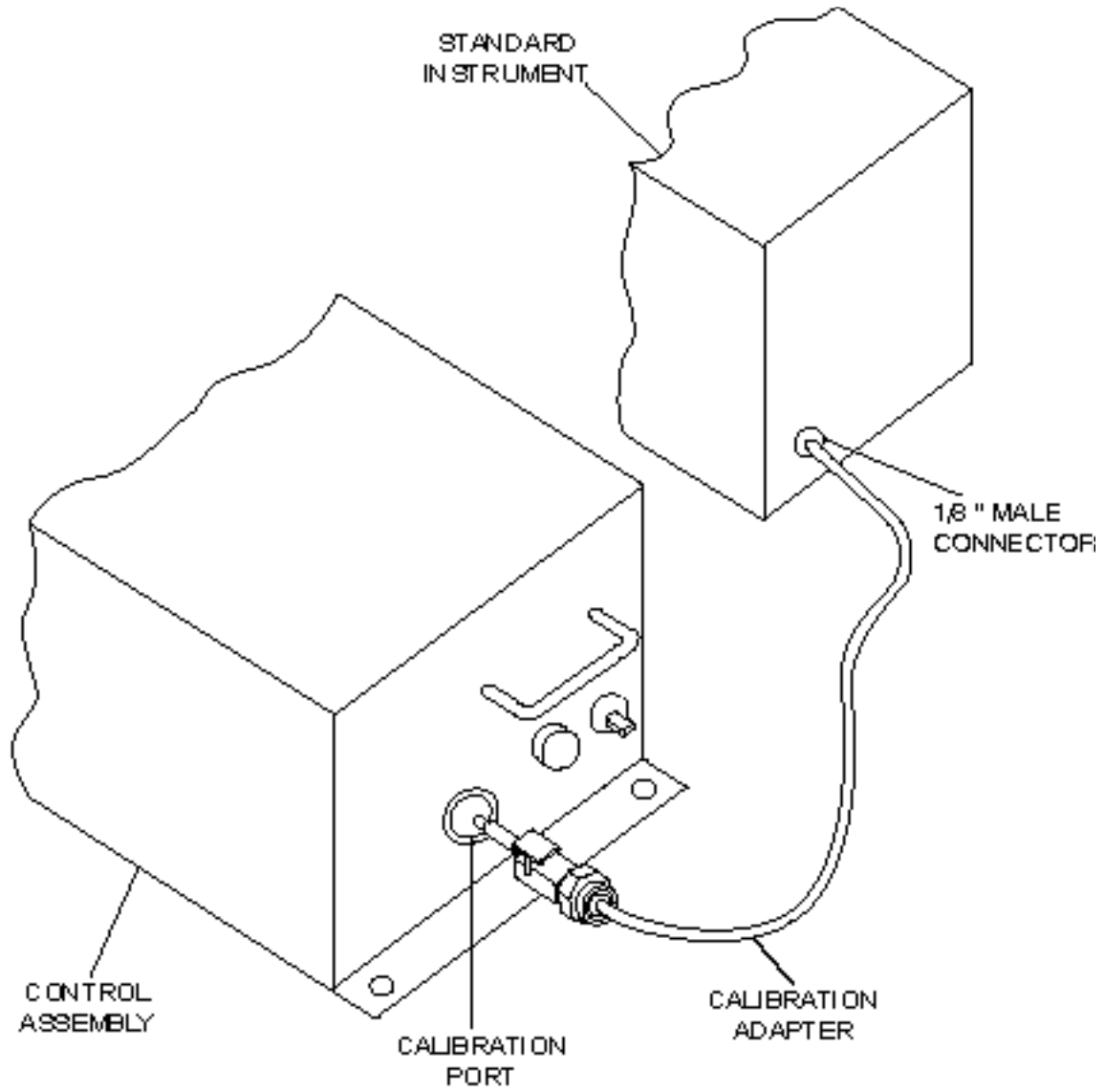

425-0025P

**ELECTRONIC TEST CHAMBER ASSEMBLY, MODEL 453
DIRECT SUPPORT MAINTENANCE**

0025 00

ALTITUDE ACCURACY VERIFICATION

7. After altitude stabilizes and ALTITUDE DWELL indicator stops flashing, observe and record altitude as observed on test chamber ALTITUDE (FT MSL) indicator.
8. Repeat step (6) and (7) for each table value.
9. All readings shall be within tolerances listed in Table 1. If not, see Zero Altitude Adjustment.

TABLE 1. ALTITUDE ERROR TOLERANCES

Standard Instrument Altitude (Feet)	Tolerance (Feet)
0	±30
1,000	35
2,000	40
3,000	45
5,000	50
8,000	60
10,000	65
12,000	70
15,000	80
18,000	90
20,000	95
25,000	105
35,000	125

10. Disconnect the entire test setup and prepare test chamber for movement (WP 0023 00)

ZERO ALTITUDE ADJUSTMENT

NOTE

Zero altitude adjustment is required if altitude accuracy is out of tolerance. Perform adjustment with unit set up as in preceding paragraphs.

1. Use SET ALTITUDE control to set standard instrument to first value in Table 1.
2. Remove top screw securing cover plate, loosen bottom screw and rotate cover plate to side, breaking calibration seal and exposing adjustable resistors.
3. Adjust ALT SET resistor screw (refer to control assembly decal); until ALTITUDE (FT MSL) display comes to within ± 5 feet of reading on standard instrument.
4. Verify tolerances for all other altitude values listed in Table 1.

NOTE

If altitude cannot be brought within prescribed accuracy tolerances, control assembly must be returned to depot for repair.

5. Reassemble cover plate and affix a calibration sticker over cover plate to prevent tampering.

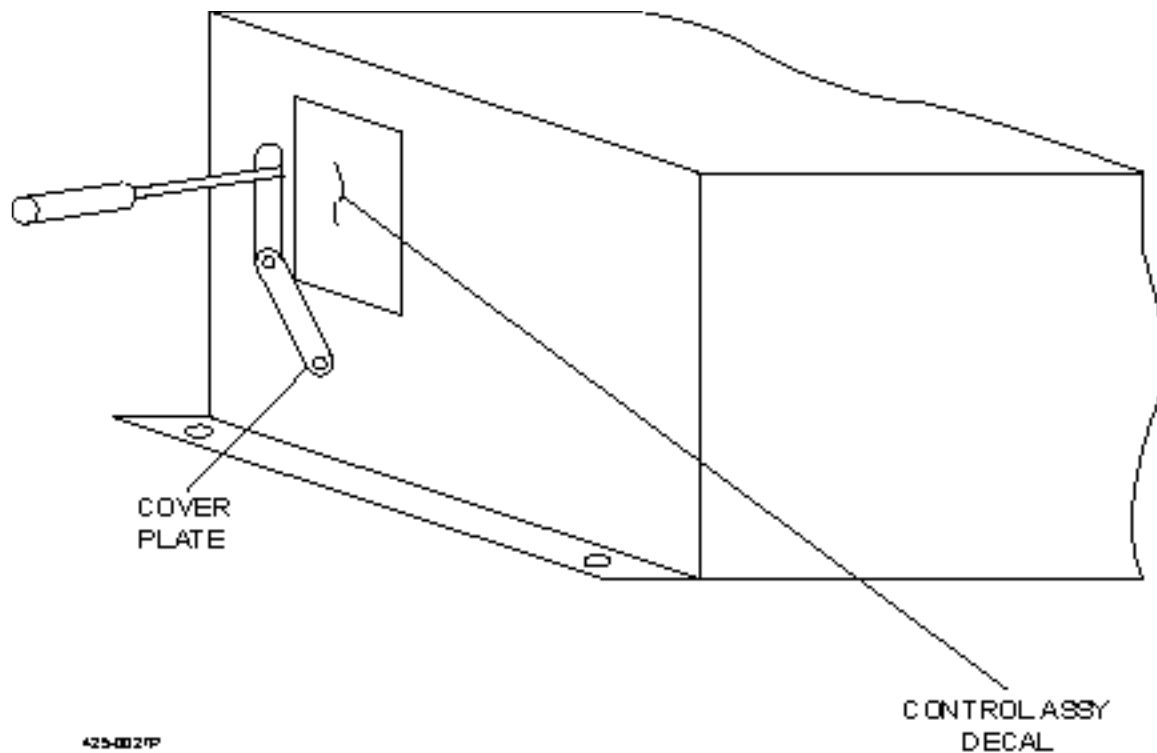

425-002/P

RATE ADJUSTMENT

This adjustment is performed in response to a reported defect from user level. The following procedure is used to correct an out of tolerance condition between the set fall rate and the actual measured rate. **The difference between the set and displayed rates cannot be affected by adjustment.**

NOTE

All four fall rate combinations; high altitude-high fall rate, high altitude-low fall rate, low altitude-high fall rate, and low altitude-low fall rate, must be evaluated together because adjustment of any one of them affects the entire range. Correct adjustment should bring all of the actual measured rates within ± 2 ft/sec of their respective set values. If this cannot be done, the Control Assembly is defective and must be replaced.

1. Perform fall rate selector accuracy test (refer to WP 0010 00) to determine at which condition(s) the fall rate is out of tolerance. It is not necessary to place an AR2 in the altitude chamber for this test, and the JUMP/OFF switch may be left in the JUMP position.
2. Open cover plate on back of control housing. Turn RATE SET resistor screw to adjust the fall rate (One half turn of the screw in the clockwise direction will lower the actual fall rate by approximately one ft/sec. The set rate is not affected by the adjustment. There is some backlash in the movement of the screw; turning past the desired position and coming back to it may be beneficial).
3. Verify that the actual fall rates are within tolerance at all four conditions.
4. Reassemble cover plate and affix calibration sticker to prevent tampering.

END OF WORK PACKAGE

THIS PAGE INTENTIONALLY LEFT BLANK

CHAPTER 6

SUPPORTING INFORMATION

FOR

AUTOMATIC RIPCORD RELEASE, AR2, MODEL 451

TEST CHAMBER ASSEMBLY, AR2, MODEL 452

ELECTRONIC TEST CHAMBER ASSEMBLY, AR2, MODEL 453

THIS PAGE INTENTIONALLY LEFT BLANK

REFERENCES

0026 00

SCOPE

This appendix contains all the pamphlets, forms and technical manuals referenced in this manual.

1. Pamphlets

DA-PAM 738-750	The Army Maintenance Management System (TAMMS)
DA-PAM 738-751	The Army Maintenance Management System-Aircraft (TAMMS-A)

2. Forms

DA Form 2028	Recommended Changes to Equipment Technical Publications
DA Form 2404	Equipment Inspection and Maintenance
DA Form 3912	Army Parachute Log Record
NAVMC 10772	Recommended Change to Publication/Logistics Maintenance Coding
SF-361	Discrepancy of Shipment Report (DSR)
SF-364	Report of Discrepancy (ROD)
SF-365	Transportation Discrepancy Report (TDR)
SF-368	Quality Deficiency Report (QDR)

3. Manuals

FM 21-11	First Aid
TM 10-1670-201-23	General Maintenance of Parachutes and Other Air Drop Equipment
NAVAIR 13-1-17	General Maintenance of Parachutes and Other Air Drop Equipment
NAVAIR 13-1-21	Organizational Maintenance with Illustrated Parts Breakdown Ram Air Parachute Assembly MT-1 XS/SL
NAVSEA SS 400-AA-MM0-010	Organizational Maintenance with Illustrated Parts Breakdown Ram Air Parachute Assembly MT-1 XS/SL
NAVSEA SS 400-AX-MM0-010	Organizational Maintenance with Illustrated Parts Breakdown Ram Air Parachute Assembly MT-1 XS/SL
TM 09770A-12&P1A	Operational Instructions and Organizational Maintenance with Illustrated Parts Breakdown Ram Air Parachute Assembly MC-5

REFERENCES - CONT

0026 00

SCOPE - CONT

TM 10-1670-287-23&P	Organizational and Direct Support Maintenance Including Repair Parts and Special Tools List for MC-4 Ram Air Free-Fall Personnel Parachute System.
TM 10-1670-300-20&P	Unit Maintenance Manual Including Repair Parts and Special Tools List for Ancillary Equipment for: Military Free-Fall System
TM 4700-15/1	Equipment Record Procedures
TM 750-244-2	Destruction of Army Materials
T.O. 13C-1-41	General Maintenance of Parachutes and Other Air Drop Equipment
4. Regulations	
AR 55-38	Reporting of Transportation Discrepancies in Shipment
AR 735-11	Accounting for Lost, Damaged, and Destroyed Property
MCO 4855.10	Product Quality Deficiency Report (PQDR)

THE ARMY MAINTENANCE SYSTEM MAC

1. This introduction (Section I) provides a general explanation of all maintenance and repair functions authorized at various maintenance levels under the Standard Army Maintenance System concept.
2. The Maintenance Allocation Chart (MAC) in Section II designates overall authority and responsibility for the performance of maintenance functions on the identified end item or component. The application of the maintenance functions to the end item or component will be consistent with the capacities and capabilities of the designated maintenance levels, which are shown on the MAC in column (4) as:

Unit-includes two subcolumns, C (operator/crew) and O (unit) maintenance.

Direct Support-includes an F subcolumn.

General Support-includes an H subcolumn.

Depot Support-includes a D subcolumn.

3. Section III lists the tools and test equipment (both special tools and common tool sets) required for each maintenance function as referenced from Section II.
4. Section IV contains supplemental instructions and explanatory notes for a particular maintenance function.

MAINTENANCE FUNCTIONS

Maintenance functions are limited to and defined as follows:

- a. **Inspect.** To determine the serviceability of an item by comparing its physical, mechanical, and/or electrical characteristics with established standards through examination (e.g. by sight, sound, or feel).
- b. **Test.** To verify serviceability by measuring the mechanical, pneumatic, hydraulic, or electrical characteristics of an item and comparing those characteristics with prescribed standards.
- c. **Service.** Operations required periodically to keep an item in proper operating condition: e.g. to clean (includes decontaminate, when required), to preserve, to drain, to paint, or to replenish fuel, lubricants, chemical fluids, or gases.
- d. **Adjust.** To maintain or regulate, within prescribed limits, by bringing into proper position, or by setting the operating characteristics to specified parameters.
- e. **Align.** To adjust specified variable elements of an item to bring about optimum or desired performance.

THE ARMY MAINTENANCE SYSTEM MAC - CONT

MAINTENANCE FUNCTIONS - CONT

- f. Calibrate. To determine and cause corrections to be made or to be adjusted on instruments or test, measuring and diagnostic equipments used in precision measurement. Consists of comparison of two instruments, one of which is a certified standard of known accuracy, to detect and adjust any discrepancy in the accuracy of the instrument being compared.
- g. Remove/Install. To remove and install the same item when required to perform service or other maintenance functions. Install may be the act of emplacing, seating, or fixing into position a spare, repair part, or module (component or assembly) in a manner to allow the proper functioning of an equipment or system.
- h. Replace. To remove an unserviceable item and install a serviceable counterpart in its place. "Replace" is authorized by the MAC and assigned maintenance level is shown as the 3rd position code of the SMR code.
- i. Repair. The application of maintenance services¹ including fault location/troubleshooting², removal/installation, and disassembly/assembly³ procedures, and maintenance actions⁴ to restore serviceability to an item by correcting specific damage, fault, malfunction, or failure in a part, subassembly, module (component or assembly), end item, or system.
- j. Overhaul. That maintenance effort (service/action) prescribed to restore an item to a completely serviceable/operational condition as required by maintenance standards in appropriate technical publications (i.e., DMWR). Overhaul is normally the highest degree of maintenance performed by the Army. Overhaul does not normally return an item to like new condition.
- k. Rebuild. Consists of those service/actions necessary for the restoration of unserviceable equipment to a like new condition in accordance with original manufacturing standards. Rebuild is the highest degree of material maintenance applied to Army equipment. The rebuild operation includes the act of returning to zero those age measurements (e.g. hours, miles) considered in classifying Army equipments/components.

¹ Services – Inspect, test, service, adjust, align, calibrate, and/or replace.

² Fault location/troubleshooting – The process of investigating and detecting the cause of equipment malfunctioning; the act of isolating a fault within a system or unit under test (UUT).

³ Disassembly/assembly – The step-by-step breakdown (taking apart) of a spare/functional group coded item to the level of its least component, that is assigned an SMR code for the level of maintenance under consideration (i.e., identified as maintenance significant).

⁴ Actions – Welding, grinding, riveting, straightening, facing, machining, and/or resurfacing.

THE ARMY MAINTENANCE SYSTEM MAC

EXPLANATION OF COLUMNS IN THE MAC, SECTION II

- a. Column 1, Group Number. Column 1 lists functional group code numbers, the purpose of which is to identify maintenance significant components, assemblies, subassemblies, and modules with the next higher assembly.
- b. Column 2, Component/Assembly. Column 2 contains the item names of components, assemblies, subassemblies, and modules for which maintenance is authorized.
- c. Column 3, Maintenance Functions. Column 3 lists the functions to be performed on the item listed in Column 2. (For detailed explanation of these functions, see MAINTENANCE FUNCTION section).
- d. Column 4, Maintenance Level. Column 4 specifies each level of maintenance authorized to perform each function listed in Column 3, by indicating work time required (expressed as manhours in whole hours or decimals) in the appropriate subcolumn. This work-time figure represents the active time required to perform that maintenance function at the indicated level of maintenance. If the number or complexity of the tasks within the listed maintenance function vary at different maintenance levels, appropriate work-time figures are to be shown for each level. The work-time figure represents the average time required to restore an item (assembly, subassembly, component, module, end item or system) to a serviceable condition under typical field operating conditions. This time includes preparation time (including any necessary disassembly/assembly time), troubleshooting/fault location time, and quality assurance time in addition to the time required to perform the specific tasks identified for the maintenance functions authorized in the allocation chart. The symbol designations for the various maintenance levels are as follows:
 - C Operator or crew maintenance
 - O Unit maintenance
 - F Direct support maintenance
 - L Specialized Repair Activity (SRA)⁵
 - H General support maintenance
 - D Depot maintenance
- e. Column 5, Tools and Test Equipment Reference Code. Column 5 specifies, by code, those common tool sets (not individual tools), common TMDE, and special tools, special TMDE, and special support equipment required to perform the designated function. Codes are keyed to tools and test equipment in Section III.
- f. Column 6, Remarks. When applicable, this column contains a letter code, in alphabetical order, which is keyed to the remarks contained in Section IV.

⁵ This maintenance level is not included in Section II, column (4) of the Maintenance Allocation Chart. Functions to this level of maintenance are identified by a work-time figure in the "H" column of Section II, column (4), and an associated reference code is used in the Remarks column (6). This code is keyed to Section IV, Remarks, and the SRA complete repair application is explained there

THE ARMY MAINTENANCE SYSTEM MAC - CONT

**EXPLANATION OF COLUMNS IN TOOLS AND TEST EQUIPMENT REQUIREMENTS,
SECTION III**

- a. Column 1, Reference Code. The tools and test equipment reference code corresponds with a code used in the MAC, Section II, Column 5.
- b. Column 2, Maintenance Level. The lowest level of maintenance authorized to use the tool or test equipment.
- c. Column 3, Nomenclature. Name or identification of the tools or test equipment.
- d. Column 4, National Stock number. The National Stock Number of the tool or test equipment.
- e. Column 5, Tool Number. The manufacturer's part number, model number, or type number.

EXPLANATION OF COLUMNS IN REMARKS, SECTION IV

- a. Column 1, Remarks Code. The code recorded in Column 6, Section II.
- b. Column 2, Remarks. This column lists information pertinent to the maintenance function being performed as indicated in the MAC, Section II.

MAINTENANCE ALLOCATION CHART (MAC)

0028 00

AUTOMATIC RIPCORD RELEASE, MODEL 451

SECTION II. MAINTENANCE ALLOCATION CHART

(1) GROUP NUMBER	(2) COMPONENT/ ASSEMBLY	(3) MAINTENANCE FUNCTION	(4) MAINTENANCE LEVEL					(5) TOOLS AND EQUIPMENT	(6) REMARKS
			UNIT		DIRECT SUPPORT	GENERAL SUPPORT	DEPOT		
			C	O	F	H	D		
01	AUTOMATIC RIPCORD RELEASE	INSPECT		0.1				1, 2 & 3	A
		TEST		0.3					D
		SERVICE		0.5					B
		REPAIR		0.4				7	C
		REPLACE		1.0					
0101	POWER CABLE ASSEMBLIES	INSPECT		0.1				4, 5 & 6	A
		REPAIR		0.4					E
		REPLACE		1.0					

SECTION III. TOOL AND EQUIPMENT LIST

(1) TOOL & EQUIP	(2) LEVEL	(3) NOMENCLATURE	(4) NATIONAL STOCK NUMBER	(5) TOOL NUMBER
1		MODEL 452 TEST CHAMBER ASSEMBLY	1670-01-370-0752	452-000
2		MODEL 453 ELECTRONIC TEST CHAMBER ASSEMBLY	1670-01-468-9471	453-001
3		SLACK CHECKER		451-230-1
4		SCREWDRIVER, PHILLIPS, NO. 2	5120-00-234-8913	
5		WRENCH, ADJUSTABLE, 6 INCH	5120-00-264-3795	
6		KNIFE		
7		SCREWDRIVER, SLOTTED, 5/32-INCH		

SECTION III. REMARKS

(1) REMARKS CODE	(2) REMARKS
A	INSPECT IS A TECHNICAL-RIGGER TYPE INSPECTION.
B	SERVICE IS CLEANING OF EQUIPMENT.
C	REPAIR IS BY REPLACEMENT OF AR2 DECALS, AND JUMP/OFF SWITCH.
D	TEST IS TO VERIFY THAT THE UNIT FUNCTIONS WITHIN SPECIFIED RANGES
E	REPAIR BY REPLACEMENT OF COMPONENTS OF POWER CABLE ASSEMBLY

MAINTENANCE ALLOCATION CHART (MAC) - CONT

0028 00

TEST CHAMBER ASSEMBLY, MODEL 452

SECTION II. MAINTENANCE ALLOCATION CHART

(1) GROUP NUMBER	(2) COMPONENT/ ASSEMBLY	(3) MAINTENANCE FUNCTION	(4) MAINTENANCE MANUAL				(5) TOOLS AND EQUIPMENT	(6) REMARKS	
			UNIT		DIRECT SUPPORT	GENERAL SUPPORT			DEPOT
			C	O	F	H			D
02	TEST CHAMBER	INSPECT TEST		0.1 1.0				A D	
		SERVICE REPAIR		1.0 1.5				B C	
0201	ALTIMETER	REPLACE CALIBRATE REPLACE			0.5			E	
							1 2, 3, 4, 5 & 6 2, 3, 4, 5 & 6 3, 4, 6		

SECTION III. TOOL AND EQUIPMENT LIST

(1) TOOL & EQUIP	(2) LEVEL	(3) NOMENCLATURE	(4) NATIONAL STOCK NUMBER	(5) TOOL NUMBER
1		MODEL 451 AUTOMATIC RIPCORDER RELEASE	1670-01-369-7914	11-1-6905-1
2		PUTTY KNIFE	5120-00-294-4605	
3		WRENCH, OPEN END, 5/8 INCH	5120-00-187-7126	
4		WRENCH, OPEN END, 11/16 INCH	5120-00-224-3160	
5		NUTDRIVER, 3/8 INCH		
6		SCREWDRIVER, SLOTTED, 1/4 INCH	5120-00-596-9364	

SECTION III. REMARKS

(1) REMARKS CODE	(2) REMARKS
A	INSPECT IS AN EXTERNAL TYPE INSPECTION.
B	SERVICE IS CLEANING OF EQUIPMENT.
C	REPAIR IS BY REPLACEMENT OF DECALS AND COMPONENTS.
D	TEST IS TO VERIFY THAT THE UNIT FUNCTIONS WITHIN SPECIFIED RANGES
E	CALIBRATION IS ACCOMPLISHED BY AVIATION INTERMEDIATE MAINTENANCE (AVIM)

MAINTENANCE ALLOCATION CHART (MAC)

0028 00

ELECTRONIC TEST CHAMBER ASSEMBLY, MODEL 453

SECTION II. MAINTENANCE ALLOCATION CHART

(1) GROUP NUMBER	(2) COMPONENT/ ASSEMBLY	(3) MAINTENANCE FUNCTION	(4) MAINTENANCE MANUAL					(5) TOOLS AND EQUIPMENT	(6) REMARKS
			UNIT		DIRECT SUPPORT	GENERAL SUPPORT	DEPOT		
			C	O	F	H	D		
03	TEST CHAMBER	INSPECT TEST SERVICE REPAIR REPLACE CALIBRATE		0.1 1.0 1.0 0.7 1.0	0.5			1 2, 3, 4, & 5 2, 3, 4, & 5 5	A D B C E

SECTION III. TOOL AND EQUIPMENT LIST

(1) TOOL & EQUIP	(2) LEVEL	(3) NOMENCLATURE	(4) NATIONAL STOCK NUMBER	(5) TOOL NUMBER
1		MODEL 451 AUTOMATIC RIPCORDER RELEASE	1670-01-369-7914	11-1-6905-1
2		NUTDRIVER, 3/8 INCH		
3		SCREWDRIVER, PHILLIPS, NO. 2 x 7 INCH	5120-00-596-0861	
4		SCREWDRIVER, PHILLIPS, NO. 3	5120-00-234-8912	
5		SCREWDRIVER, SLOTTED, 3/32 INCH	5120-00-720-4969	

SECTION III. REMARKS

(1) REMARKS CODE	(2) REMARKS
A	INSPECT IS AN EXTERNAL TYPE INSPECTION.
B	SERVICE IS CLEANING OF EQUIPMENT.
C	REPAIR IS BY REPLACEMENT OF DECALS AND COMPONENTS.
D	TEST IS TO VERIFY THAT THE UNIT FUNCTIONS WITHIN SPECIFIED RANGES
E	CALIBRATION IS ACCOMPLISHED BY AVIATION INTERMEDIATE MAINTENANCE (AVIM) NOTE: TM must accompany Test Chamber AVIM

THIS PAGE INTENTIONALLY LEFT BLANK

REPAIR PARTS AND SPECIAL TOOL LIST (RPSTL)

0029 00

SCOPE

This RPSTL lists and authorizes spares and repair parts; special tools; special test, measurement, and diagnostic equipment (TMDE); and other special support equipment required for performance of operation level maintenance of the following:

- (1) Automatic Ripcord Release, AR2, Model 451
- (2) Test Chamber Assembly, AR2, Model 452
- (3) Electronic Test Chamber Assembly, AR2, Model 453.

Each will have its own work package. It authorizes the requisitioning, issue, and disposition of spares, repair parts, and special tools as indicated by the source, maintenance, and recoverability (SMR) codes.

GENERAL

In addition to the introduction work package, this RPSTL is divided into the following work packages.

1. **Repair Parts List Work Packages.** Work packages containing lists of spares and repair parts authorized by this RPSTL for use in the performance of maintenance. These work packages also include parts which must be removed for replacement of the authorized parts. Parts lists are composed of functional groups in ascending alphanumeric sequence, with the parts in each group listed in ascending figure and item number sequence. Sending units, brackets, filters, and bolts are listed with the component they mount on. Bulk materials are listed by item name in FIG. BULK at the end of the work packages. Repair parts kits are listed separately in their own functional group and work package. Repair parts for reparable special tools are also listed in a separate work package. Items listed are shown on the associated illustrations.
2. **Special Tools List Work Packages.** Work packages containing lists of special tools, special TMDE, and special support equipment authorized by this RPSTL (as indicated by Basis of Issue (BOI) information in the DESCRIPTION AND USABLE ON CODE (UOC) column). Tools that are components of common tool sets and/or Class VII are not listed.
3. **Cross-Reference Indexes Work Packages:** There are cross-reference indexes work packages in the RPSTL: the national Stock Number (NSN) Index work package and the Part number (P/N) Index work package. The National Stock Number Index work package refers you to the figure and item number. The Part Number Index work package refers you to the figure and item number.

EXPLANATION OF COLUMNS IN THE REPAIR PARTS LIST AND SPECIAL TOOLS LIST WORK PACKAGES

Item no. (Column (1)). Indicates the number used to identify items called out in the illustration.

SMR CODE (Column (2)). The SMR code containing supply/requisitioning information, maintenance level authorization criteria, and disposition instructions as shown in the following breakout:

REPAIR PARTS AND SPECIAL TOOL LIST (RPSTL) – CONT

0029 00

GENERAL – CONT

SOURCE CODE	MAINTENANCE CODE		RECOVERABILITY CODE
XX	XX		X
1ST TWO POSITIONS: HOW TO GET AN ITEM.	3 RD POSITION: WHO CAN INSTALL, REPLACE, OR USE THE ITEM.	4 TH POSITION: WHO CAN DO COMPLETE REPAIR* ON THE ITEM.	5 TH POSITION: WHO DETERMINES DISPOSITION ACTION ON UNSERVICEABLE ITEMS.

*Complete Repair: Maintenance capacity, capability, and authority to perform all corrective maintenance tasks of the "Repair" function in a use/user environment in order to restore serviceability to a failed item.

SOURCE CODE

The source code tells you how you get an item needed for maintenance, repair, or overhaul of an end item/equipment. Explanation of Source Codes follow:

SOURCE CODE	APPLICATION/EXPLANATION
PA	Stock items; use the applicable NSN to requisition/request items with these source codes.
PB	They are authorized to the level indicated by the code entered in the 3 rd position of the SMR code.
PC	
PD	NOTE: Items coded PC are subject to deterioration.
PE	
PF	
PG	
KD	Items with these codes are not to be requested/requisitioned individually. They are part of a kit which is authorized to the maintenance level indicated in the 3 rd position of the SMR code. The complete kit must be requisitioned and applied.
KF	
KB	

MO-Made at unit/ AVUM level	Items with these codes are not to be requisitioned/requested individually. They must be made from bulk material which is identified by the P/N in the DESCRIPTION AND USABLE ON CODE (UOC) column and listed in the bulk material group work package of the RPSTL. If the item is authorized to you by the 3 rd position code of the SMR code, but the source code indicates it is made at higher level, order the item from the higher level of maintenance.
MF-Made at DS/ AVIM level	
MH-Made at GS level	
ML-Made at SRA	
MD-Made at depot	

REPAIR PARTS AND SPECIAL TOOL LIST (RPSTL)

0029 00

GENERAL

<p>AO-Assembled by unit/AVUM level AF-Assembled by DS/AVIM level AH-Assembled by GS level AL-Assembled by SRA AD-Assembled by depot</p>	<p>Items with these codes are not to be requested /requisitioned individually. The parts that make up the assembled item must be requisitioned or fabricated and assembled at the level of maintenance indicated by the source code. If the 3rd position of the SMR code authorizes you to replace the item, but the source code indicated the item is assembled at a higher level, order the item from the higher level of maintenance..</p>
---	--

- | | |
|-----------|---|
| <p>XA</p> | <p>Do not requisition an "XA" coded item. Order the next higher assembly. (Refer to NOTE below).</p> |
| <p>XB</p> | <p>If an item is not available from salvage, order it using the CAGEC and P/N.</p> |
| <p>XC</p> | <p>Installation drawings, diagrams, instruction sheets, field service drawings; identified by manufacture's P/N.</p> |
| <p>XD</p> | <p>Item is not stocked. Order an XD-coded item through normal supply channels using the CAGEC and P/N given, if no NSN is available</p> |

NOTE

Cannibalization or controlled exchange, when authorized, may be used as a source of supply for items with the above source codes except for those items source coded "XA" or those aircraft support items restricted by requirements of AR750-1.

Maintenance Code. Maintenance codes tell you the level(s) of maintenance authorized to use and repair support items. The maintenance codes are entered in the third and fourth positions of the SMR code as follows:

Third Position. The maintenance code entered in the third position tells you the lowest maintenance level authorized to remove, replace, and use an item. The maintenance code entered in the third position will indicate authorization to the following levels of maintenance:

REPAIR PARTS AND SPECIAL TOOL LIST (RPSTL) - CONT

0029 00

GENERAL - CONT

MAINTENANCE CODE	APPLICATION/EXPLANATION
C	Crew or operator maintenance done within unit /AVUM maintenance.
O	Unit level/AVUM maintenance can remove, replace, and use the item.
F	Direct support/AVIM maintenance can remove, replace, and use the item.
H	General support maintenance can remove, replace, and use the item.
L	Specialized repair activity can remove, replace, and use the item.
D	Depot can remove, replace, and use the item.

Fourth Position. The maintenance code entered in the fourth position tells you whether or not the item is to be repaired and identifies the lowest maintenance level with the capability to do complete repair (perform all authorized repair functions).

NOTE

Some limited repair may be done on the item at a lower level of maintenance, if authorized by the Maintenance Allocation Chart (MAC) and SMR codes.

MAINTENANCE CODE	APPLICATION/EXPLANATION
O	Unit/AVUM is the lowest level that can do complete repair of the item.
F	Direct support/AVIM is the lowest level that can do complete repair of the item.
H	General support is the lowest level that can do complete repair of the item.
L	Specialized repair activity (operator) is the lowest level that can do complete repair of the item.
D	Depot is the lowest level that can do complete repair of the item.
Z	Nonreparable. No repair is authorized.
B	No repair is authorized. No parts or special tools are authorized for maintenance of "B" coded item. However, the item may be reconditioned by adjusting, lubrication, etc., at the user level.

Recoverability Code. Recoverability codes are assigned to items to indicate the disposition action on unserviceable items. The recoverability code is shown in the fifth position of the SMR code as follows:

REPAIR PARTS AND SPECIAL TOOL LIST (RPSTL)

0029 00

GENERAL

RECOVERABILITY CODE	APPLICATION/EXPLANATION
Z	Nonreparable item. When unserviceable, condemn and dispose of the item at the level of maintenance shown in the third position of the SMR code.
O	Reparable item. When uneconomically repairable, condemn and dispose of the item at the unit level.
F	Reparable item. When uneconomically repairable, condemn and dispose of the item at the direct support level.
H	Reparable item. When uneconomically repairable, condemn and dispose of the item at the general support level.
D	Reparable item. When beyond lower level repair capability, return to depot. Condemnation and disposal of item are not authorized below depot level.
L	Reparable item. Condemnation and disposal not authorized below Specialized Repair Activity (SRA).
A	Item requires special handling or condemnation procedures because of specific reasons (such as precious metal content, high dollar value, critical material, or hazardous material). Refer to appropriate manuals /directives for specific instructions.

NSN (Column (3)). The NSN for the item is listed in this column.

CAGEC (Column (4)). The commercial and Government Entity Code (CAGEC) is a five-digit code which is used to identify the manufacturer, distributor, or Government agency/activity that supplies the item.

PART NUMBER (Column (5)). Indicates the primary number used by the manufacturer (individual, company, firm, corporation, or Government activity), which controls the design and characteristics of the item by means of its engineering drawings, specifications, standards, and inspection requirements to identify an item or range of items.

NOTE

When you use an NSN to requisition an item, the item you receive may have a different P/N from the number listed.

DESCRIPTION AND USABLE ON CODE (UOC) (Column (6)). This column includes the following information:

REPAIR PARTS AND SPECIAL TOOL LIST (RPSTL) - CONT

0029 00

GENERAL - CONT

1. The federal item name, and when required, a minimum description to identify the item.
2. P/Ns of bulk materials are referenced in this column in the line entry to be manufactured or fabricated.
3. Hardness Critical Item (HCI). A support item that provides the equipment with special protection from electromagnetic pulse (EMP) damage during a nuclear attack.
4. The statement END of FIGURE appears just below the last item description in column (6) for a given figure in both the repair parts list and special tools list work packages.
5. QTY (column (7)). The QTY (quantity per figure) column indicates the quantity of the item used in the breakout shown on the illustration/figure, which is prepared for a functional group, subfunctional group, or an assembly. A "V" appearing in this column instead of a quantity indicates that the quantity is variable and quantity may change from application to application.

**EXPLANATION OF CROSS-REFERENCE INDEXES
WORK PACKAGES FORMAT AND COLUMNS**

1. National Stock Number (NSN) Index Work Package.

STOCK NUMBER Column. This column lists the NSN in National item identification number (NIIN) sequence. The NIIN consists of the last nine digits of the NSN.

NSN (e.g., 5385-01-574-1476)	
NIIN	

When using this column to locate an item, ignore the first four digits of the NSN. However, the complete NSN should be used when ordering items by stock number.

FIG. Column. This column lists the number of the figure where the item is identified/located. The figures are in numerical order in the repair parts list and special tools list work packages.

ITEM Column. Th item number identifies the item associated with the figure listed in the adjacent FIG. Column. This item is also identified by the NSN listed on the same line.

2. Part Number (P/N) Index Work package. P/Ns in this index are listed in ascending alphanumeric sequence (vertical arrangement of letter and number combinations which places the first letter or digit of each group in order A through Z, followed by the numbers 0 through 9 and each following letter or digit in like order).

PART NUMBER Column. Indicates the P/N assigned to the item.

FIG. Column. This column lists the number of the figure where the item is identified/located in the repair parts list and special tools list work packages.

ITEM Column. The item number is the number assigned to the item as it appears in the figure referenced in the adjacent figure number column."

REPAIR PARTS AND SPECIAL TOOL LIST (RPSTL)

0029 00**GENERAL****INDEX NUMBERS**

Items which have the word BULK in the figure column will have an index number shown in the item number column. This index number is a cross references between the NSN/PN index work packages and the BULK material list in the repair parts list work package.

REFERENCE DESIGNATOR Column. Indicates the reference designator assigned to the item.

SPECIAL INFORMATION**“HOW TO LOCATE REPAIR PARTS”****1. When NSNs or P/Ns are not known.**

First. Using the table of contents, determine the assembly group to which the item belongs. This is necessary since figures are prepared for assembly groups, and lists are divided into the same groups.

Second. Find the figure covering the functional group or the subfunctional group to which the item belongs.

Third. Identify the item on the figure and note the number(s).

Fourth. Look in the repair parts list work packages for the figure and item numbers. The NSNs and part numbers are on the same line as the associated item numbers.

2. When NSN Is Known.

First. If you have the NSN, look in the STOCK NUMBER column of the NSN index work package. The NSN is arranged in NIIN sequence. Note the figure and item number next to the NSN.

Second. Turn to the figure and locate the item number. Verify that the item is the one you are looking for.

3. When P/N is Known.

First. If you have the P/N and not the NSN, look in the Part Number column of the P/N index work package. Identify the figure and item number.

Second. Look up the item on the figure in the applicable repair parts list work package.

ABBREVIATIONS

Not Applicable

THIS PAGE INTENTIONALLY LEFT BLANK

THIS PAGE INTENTIONALLY LEFT BLANK

AUTOMATIC RIPCORD RELEASE, MODEL 451
REPAIR PARTS LIST

0030 00

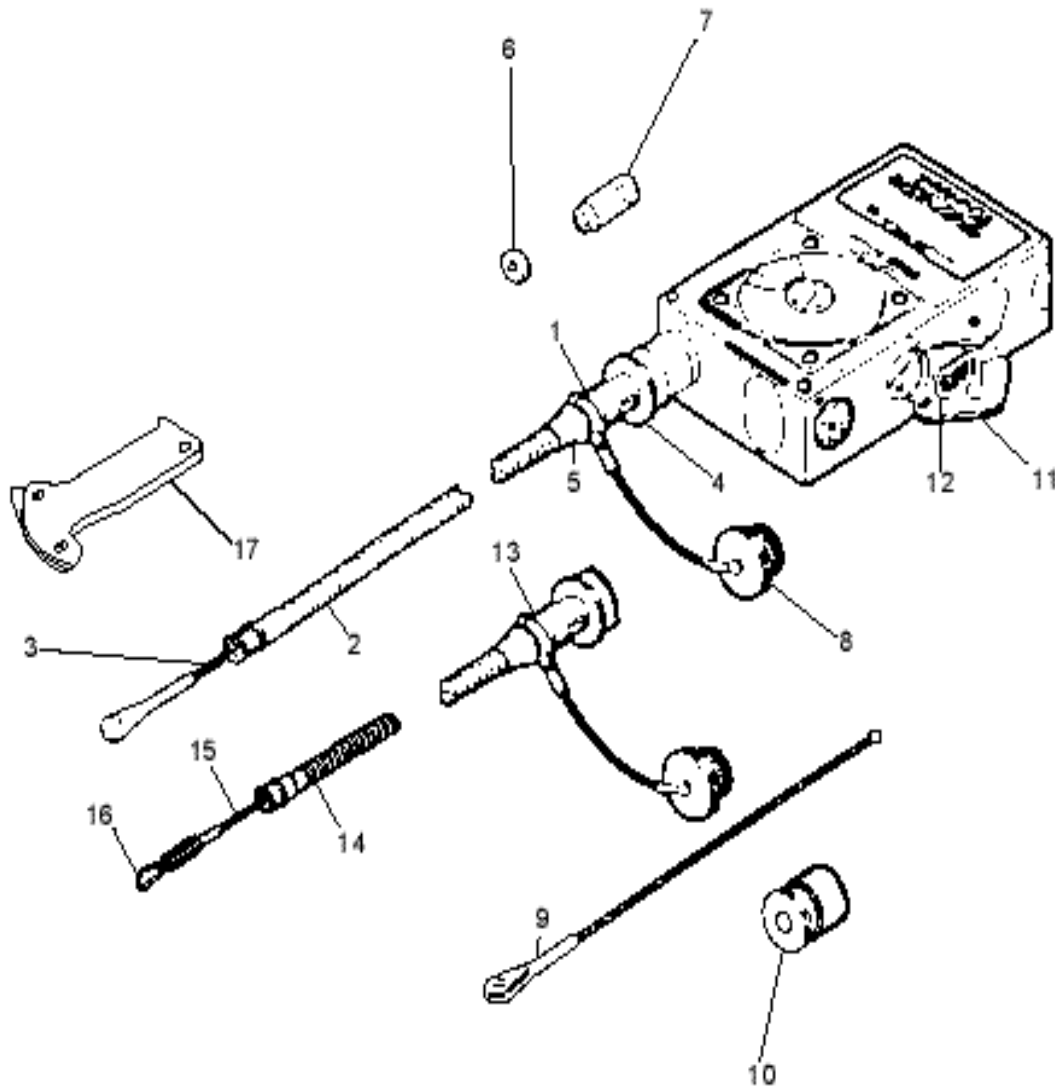

FIGURE 1. AUTOMATIC RIPCORD RELEASE, MODEL 451

451-000 TP

**AUTOMATIC RIPCORD RELEASE, MODEL 451
REPAIR PARTS LIST**

0030 00

(1) ITEM NO.	(2) SMR CODE	(3) NATIONAL STOCK NUMBER	(4) CAGEC	(5) PART NUMBER	(6) DESCRIPTION AND USABLE ON CODE	(7) QTY
	PAODD	1670-01-369-7914	81337	11-1-6905-1	GROUP 01 RIPCORD RELEASE ASSY, AUTOMATIC, MODEL 451	REF
					FIGURE 1 RIPCORD RELEASE ASSY, AUTOMATIC, MODEL 451	
1	PAOZZ	6150-01-390-4709	81337	11-1-6906-1	. . POWER CABLE ASSY, MAIN	1
2	XDOZZ		81337	11-1-6924-1	. . POWER HOUSING (FIXED EYE)	1
3	XDOZZ		81337	11-1-6925-1	. . POWER CABLE ASSY (FIXED EYE)	1
4	XDOZZ		26309	451-059	. . RETAINER POWER HOUSING	1
5	XDOZZ		91906	MS27426- 1103D	. . RING RETAINING	1
6	PAOZZ	5330-01-390-4719	81337	11-1-6913-1	. . SEAL, POWER CABLE	1
7	PAOZZ	5330-01-390-4720	81337	11-1-6914-1	. . RETAINER CABLE SEAL	1
8	PAOZZ	1670-01-428-3865	81337	11-1-4052-1	. . LANYARD ASSY	1
9	XDOZZ		81337	11-1-6923-1	. . CABLE, STORAGE	1
10	PAOZZ	1670-01-428-9252	81337	11-1-4053-1	. . CAP, PISTON ROD	1
11	PAOZZ	5930-01-390-4706	81337	11-1-6908-1	. . SWITCH ASSY, JUMP/OFF	1
12	PAOZZ	7960-01-390-4702	81337	11-1-6909-1	. . DECAL, JUMP/OFF	1
13	PAOZZ	6150-01-390-4711	81337	11-1-6906-2	. . POWER CABLE ASSY, RSV	1
14	XDOZZ		81337	11-1-6924-2	. . POWER HOUSING (DETACHABLE EYE)	1
15	XDOZZ		81337	11-1-6925-2	. . POWER CABLE ASSY (DETACHABLE EYE)	1
16	PAOZZ	5340-01-390-4715	81337	11-1-6912-1	. . EYE, DETACHABLE, RIPCORD RELEASE	1
17	XDOZZ		26309	451-230-1	SLACK CHECKER, RIPCORD RELEASE	REF
					END OF FIGURE	

END OF WORK PACKAGE

THIS PAGE INTENTIONALLY LEFT BLANK

TEST CHAMBER ASSEMBLY, MODEL 452
REPAIR PARTS LIST

0031 00

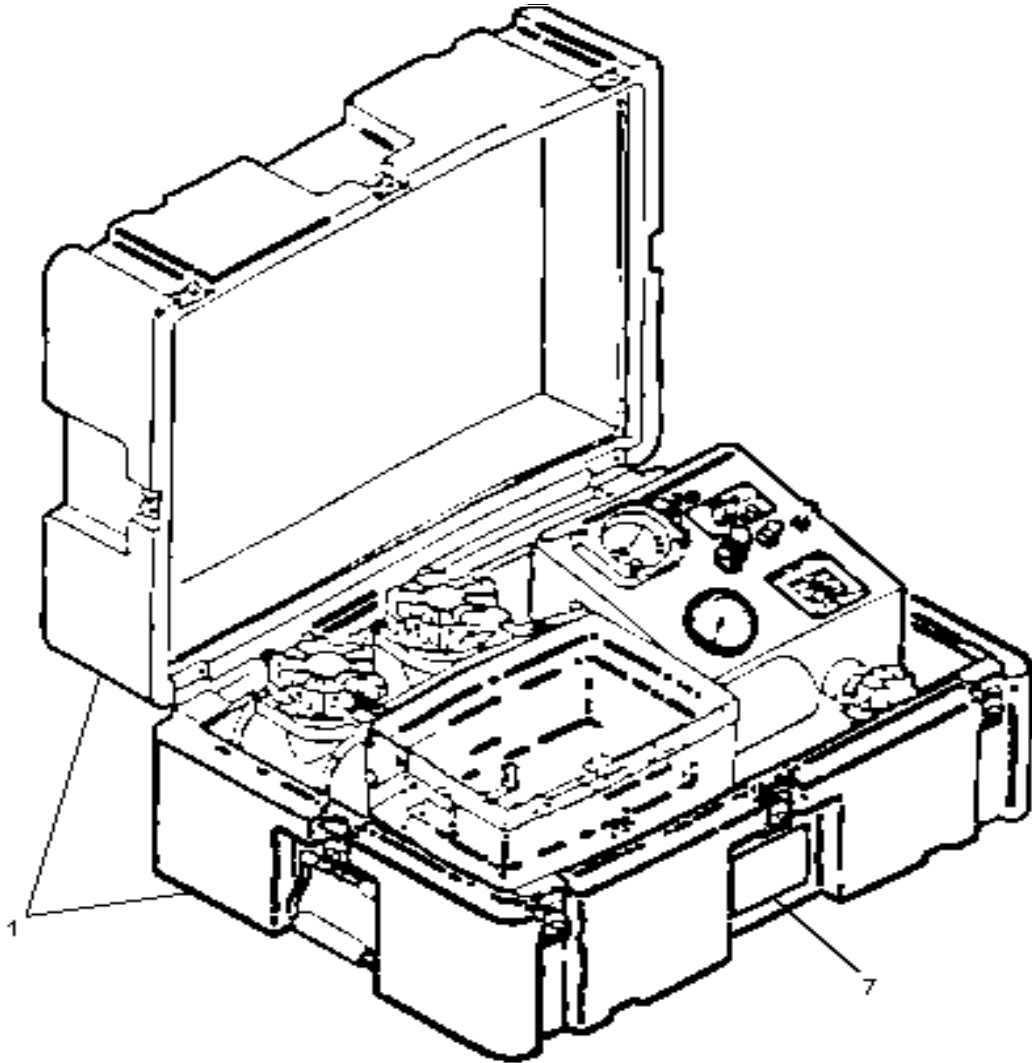

FIGURE 2 TEST CHAMBER ASSEMBLY, MODEL 452(SHEET 1 of 2)

425-00 000

TEST CHAMBER ASSEMBLY, MODEL 452
REPAIR PARTS LIST - CONT

0031 00

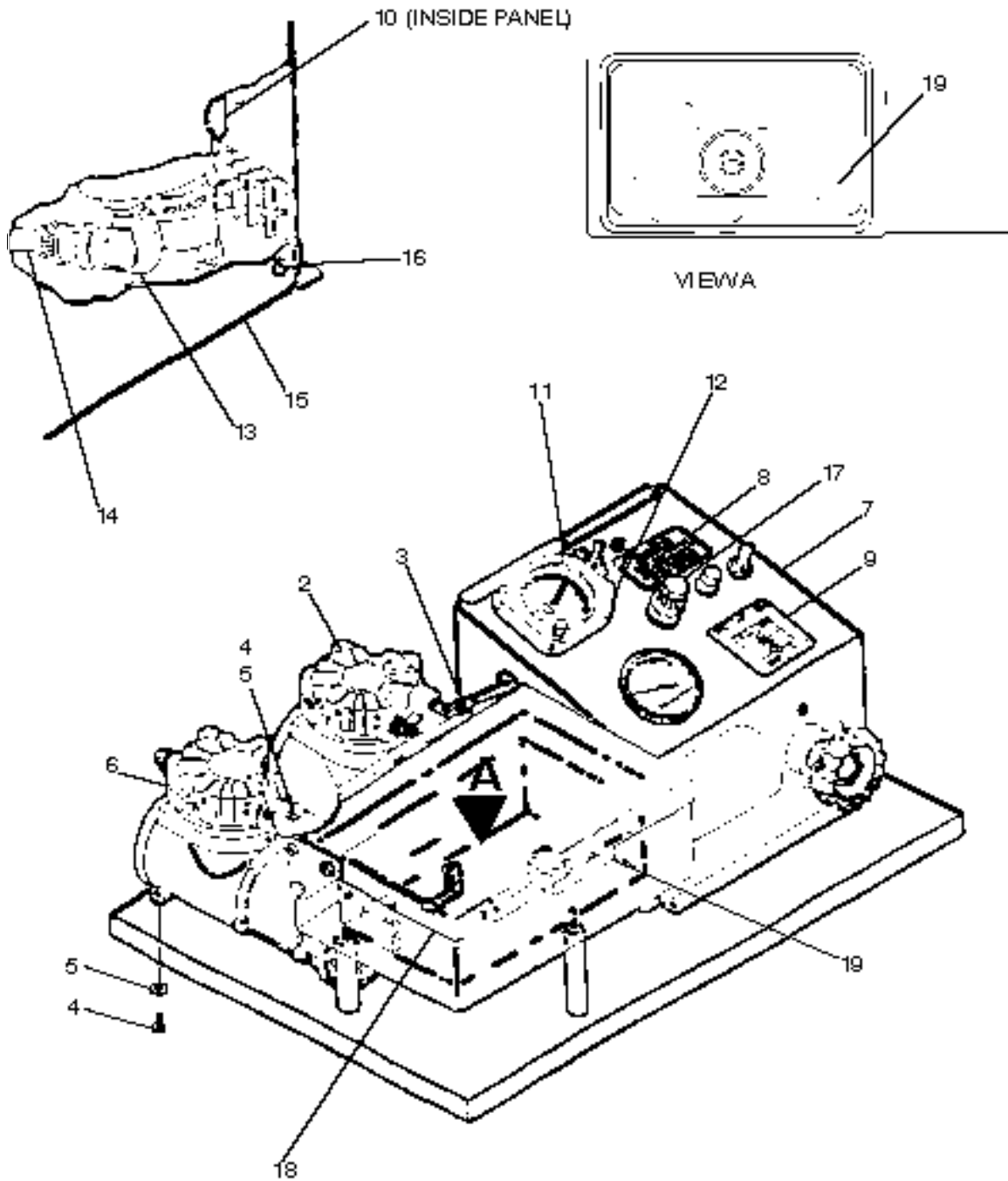

FIGURE 1. TEST CHAMBER ASSEMBLY, MODEL 452 (SHEET 2 of 2)

42-0000

**TEST CHAMBER ASSEMBLY, MODEL 452
REPAIR PARTS LIST**

0031 00

(1) ITEM NO.	(2) SMR CODE	(3) NATIONAL STOCK NUMBER	(4) CAGEC	(5) PART NUMBER	(6) DESCRIPTION AND USABLE ON CODE	(7) QTY
	PAOFF	1670-01-370-0752	81337	11-1-6915-1	GROUP 02 TEST CHAMBER ASSY, MODEL 452	REF
1	XDOZZ		26309	452-101	CASE, CARRYING	1
2	PAOZZ	4320-01-390-4723	81337	11-1-6916-1	PUMP, VACUUM	1
3	PAOZZ	3040-00-855-2020	30327	261-P-04	NUT AND PLASTIC SLEEVE ASSY	2
4	XDOZZ		26309	452-129	SCREW, SELF LOCKING	3
5	XDOZZ		26309	452-224	WASHER, FLAT	3
6	PAOZZ	4310-01-390-4722	81337	11-1-6916-2	COMPRESSOR,AIR	1
7	XDOZZ		26309	452-135	DECAL, IDENTIFICATION	2
8	XDOZZ		26309	452-134	DECAL, WARNING	1
9	XDOZZ		26309	452-133	DECAL, FUNCTIONS	1
10	XDOZZ		26309	452-157	DECAL, CONNECTIONS	1
11	PAOFF	6610-00-110-3368	81349	AAU-31/A-1	ALTIMETER	1
12	PAOZZ		26309	452-212	SCREW, BINDING HD SLTD	3
13	PAOZZ	4730-01-397-7890	02570	SS-600-2- 6STKN	ELBOW, MALE	1
14	XDOZZ		26309	452-203	TUBING, POLY	1
15	XDOZZ		26309	452-132	PANEL, HOUSING	1
16	PAOZZ		26309	452-213	SCREW, TRUSS HD SLTD	4
17	PAOZZ	5920-00-270-5179	75915	313005	FUSE	1
18	XDOZZ	1670-01-390-4718	81337	11-1-4051-1	GASKET	1
19	XDOZZ		26309	453-099	SUPPORT, COCKING	1
					END OF FIGURE	

END OF WORK PACKAGE

THIS PAGE INTENTIONALLY LEFT BLANK

THIS PAGE INTENTIONALLY LEFT BLANK

ELECTRONIC TEST CHAMBER ASSEMBLY, MODEL 453
REPAIR PARTS LIST

0032 00

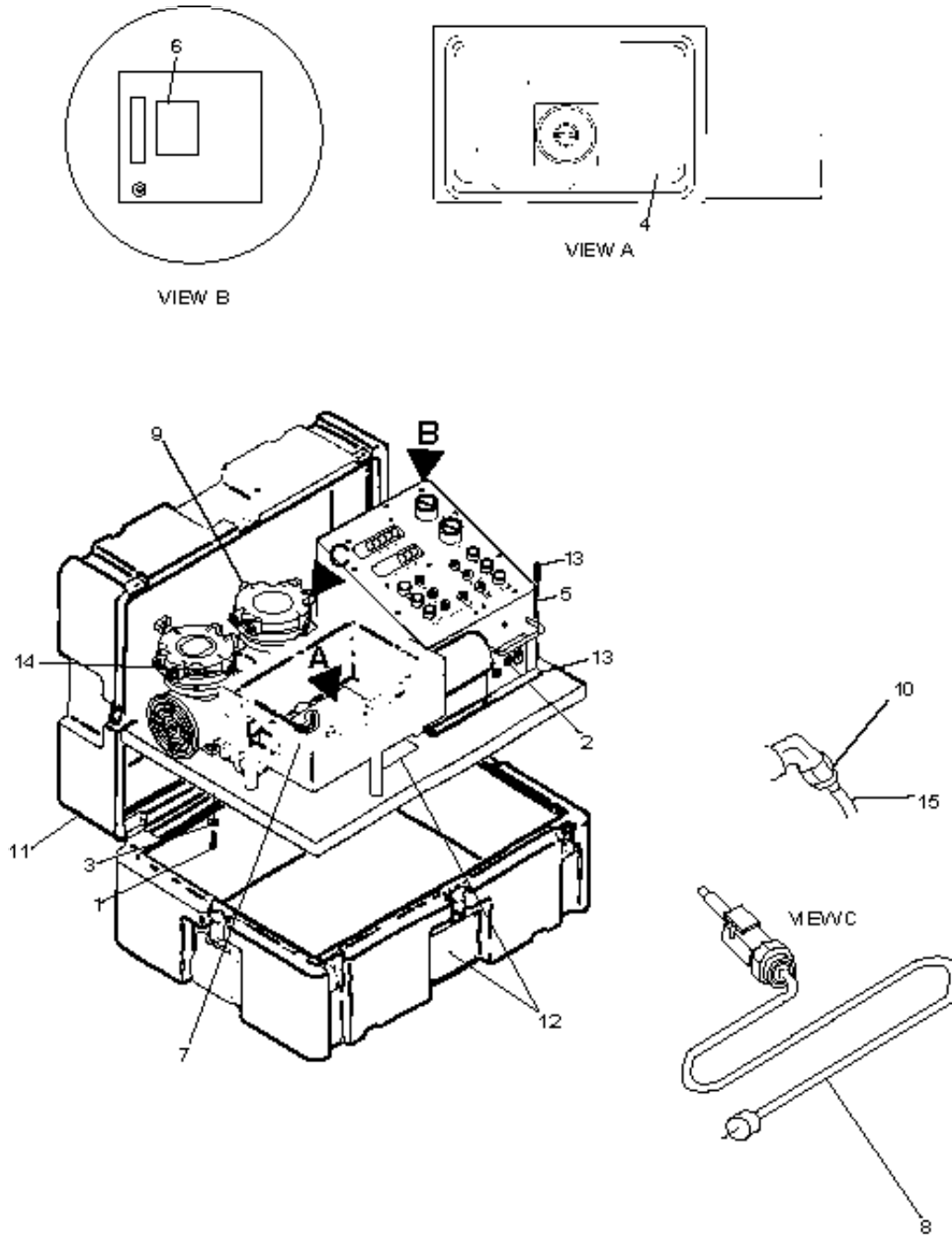

FIGURE 1 MODEL 453 ELECTRONIC TEST CHAMBER

425-0022P

**ELECTRONIC TEST CHAMBER ASSEMBLY, MODEL 453
REPAIR PARTS LIST**

0032 00

(1) ITEM NO.	(2) SMR CODE	(3) NATIONAL STOCK NUMBER	(4) CAGEC	(5) PART NUMBER	(6) DESCRIPTION AND USABLE ON CODE	(7) QTY
	PAOOD	1670-01-468-9471	81377	11-1-4150-1	GROUP 03 ELECTRONIC TEST CHAMBER ASSEMBLY, MODEL 453 FIGURE 3 ELECTRONIC TEST CHAMBER ASSEMBLY, MODEL 453	REF
1	XDOZZ		26309	452-129	SCREW, SELF LOCKING	4
2	PAOZZ	5920-00-270-5179	75915	313005	FUSE	1
3	XDOZZ		26309	452-224	WASHER, FLAT	4
4	XDOZZ		26309	453-099	SUPPORT, COCKING	1
5	PAODD		81337	11-1-4154-1	ASSY, CONTROL	1
6	XDOZZ		26309	453-165	DECAL, CONTROL ASSY	1
7	XDOZZ		81337	11-1-4156-1	GASKET	1
8	XDOZZ		26309	453-280	ADAPTER, CALIBRATION	1
9	PAOZZ		81337	11-1-4151-1	ASSY, VAC PUMP/COMPRESSOR	1
10	PAOZZ	3040-00-855-2020	30327	261-P-04	NUT AND PLASTIC SLEEVE ASSY	10
11	XDOZZ		26309	453-450-1	CASE, CARRYING	1
12	XDOZZ		26309	453-451	DECAL, IDENTIFICATION	2
13	PAOZZ		96904	MS51597-81	SCREW, PAN HD PHILLIPS	4
14	XDOZZ		26309	453-542	TUBING, BLACK POLYURETHANE (1 FOOT LONG)	1
15	XDOZZ		26309	453-543	TUBING, BLUE POLYURETHANE (1 FOOT LONG) END OF FIGURE	4

END OF WORK PACKAGE

THIS PAGE INTENTIONALLY LEFT BLANK

NATIONAL STOCK NUMBER INDEX

0033 00

NATIONAL STOCK NUMBER	FIGURE NO.	ITEM NO.	NATIONAL STOCK NUMBER	FIGURE NO.	ITEM NO.
1670-01-369-7914	0030-1		7960-01-390-4702	0030-1	12
1670-01-370-0752	0031-2				
1670-01-390-4718	0031-2	18			
1670-01-428-3865	0030-1	8			
1670-01-428-7637	0030-1	17			
1670-01-428-9252	0030-1	10			
1670-01-468-9471	0032-3				
3040-00-855-2020	0031-2	3			
4310-01-390-4722	0031-2	6			
4320-01-390-4723	0031-2	2			
4730-01-397-7890	0031-2	13			
5330-01-390-4719	0030-1	6			
5330-01-390-4720	0030-1	7			
5340-01-390-4715	0030-1	16			
5920-00-270-5179	0031-2	17			
5920-00-270-5179	0032-3	2			
5930-01-390-4706	0030-1	11			
6150-01-390-4709	0030-1	1			
6150-01-390-4711	0030-1	13			
6610-00-110-3368	0031-2	11			

THIS PAGE INTENTIONALLY LEFT BLANK

PART NUMBER INDEX

0034 00

PART NUMBER	FIGURE NO.	ITEM NO.	PART NUMBER	FIGURE NO.	ITEM NO.
AAU-31/A-1	0031-2	11	11-1-6916-2	0031-2	6
MS27426-1103D	0030-1	5	11-1-6923-1	0030-1	9
MS51597-81	0032-3	13	11-1-6924-1	0030-1	2
SS-600-2-6STKN	0031-2	13	11-1-6924-2	0030-1	14
11-1-4051-1	0031-2	18	11-1-6925-1	0030-1	3
11-1-4052-1	0030-1	8	11-1-6925-2	0030-1	15
11-1-4053-1	0030-1	10	261-P-04	0031-2	3
11-1-4054-1	0030-1	13	261-P-04	0032-3	10
11-1-4150-1	0032-3		313005	0031-2	17
11-1-4154-1	0032-3	5	313005	0032-3	2
11-1-4156-1	0032-3	7	451-059	0030-1	4
11-1-4151-1	0032-3	9	451-230-1	0030-1	18
11-1-6905-1	0030-1		452-101	0031-2	1
11-1-6906-1	0030-1	1	452-129	0031-2	4
11-1-6906-2	0030-1	13	452-129	0032-3	1
11-1-6908-1	0030-1	11	452-132	0031-2	15
11-1-6909-1	0030-1	12	452-133	0031-2	9
11-1-6912-1	0030-1	16	452-134	0031-2	8
11-1-6913-1	0030-1	6	452-135	0031-2	7
11-1-6914-1	0030-1	7	452-157	0031-2	10
11-1-6915-1	0031-2		452-203	0031-2	14
11-1-6916-1	0031-2	2	452-212	0031-2	12

PART NUMBER INDEX - CONT

0034 00

PART NUMBER	FIGURE NO.	ITEM NO.	PART NUMBER	FIGURE NO.	ITEM NO.
452-213	0031-2	16			
452-224	0031-2	5			
452-224	0032-3	3			
453-099	0032-3	4			
453-099	0031-2	19			
453-165	0032-3	6			
453-280	0032-3	8			
453-450-1	0032-3	11			
453-451	0032-3	12			
453-542	0032-3	14			
453-543	0032-3	15			

**COMPONENTS OF END ITEMS (COEI) AND BASIC ISSUE ITEMS (BII)
INTRODUCTION**

0035 00

SCOPE

This work package lists COEI and BII for the Model 451 Automatic Ripcord Release, Model 452 Test Chamber Assembly, and Model 453 Electronic Test Chamber Assembly, to help you inventory items for safe and efficient operation of the equipment.

GENERAL

The COEI and BII information is divided into the following lists:

Components of End Item (COEI). This list is for information purposes only and is not authority to requisition replacements. These items are part of the applicable unit. As part of the end item, these items must be with the end item whenever it is issued or transferred between property accounts. Items of COEI are removed and separately packaged for transportation or shipment only when necessary. Illustrations are furnished to help you find and identify the items.

Basic Issue Items (BII). These essential items are required to place the applicable unit in operation, operate it, and to do emergency repairs. Although shipped separately packaged, BII must be with the units during operation and when it is transferred between property accounts. Listing these items is your authority to request/requisition them for replacement based on authorization of the end item by the TOE/MTOE. Illustrations are furnished to help you find and identify the items.

Explanation of Columns in the COEI List and BII List

Column (1), Illus. Number, gives you the number of the item illustrated.

Column (2), National Stock Number, identifies the stock number of the item to be used for requisitioning purposes.

Column (3), Description, CAGEC, and part number, identifies the Federal item name (in all capital letters) followed by a minimum description when needed. The stowage location of COEI and BII is also included in this column. The last line below the description is the CAGEC (Commercial and Government entity code) (in parentheses) and the part number.

Column (4), Usable on code, gives you a code if the item you need is not the same for different models of equipment. These codes are identified below:

Code	Used on
------	---------

Column (5), U/M (unit of measure), indicates how the item is issued for the National Stock Number shown in column (2).

Column (6), Qty Rqr, indicates the quantity required.

THIS PAGE INTENTIONALLY LEFT BLANK

**AUTOMATIC RIPCORD RELEASE, MODEL 451
COMPONENTS OF END ITEMS (COEI) AND BASIC ISSUE ITEMS (BII)**

0036 00

COMPONENTS OF END ITEM (COEI), AUTOMATIC RIPCORD RELEASE, MODEL 451

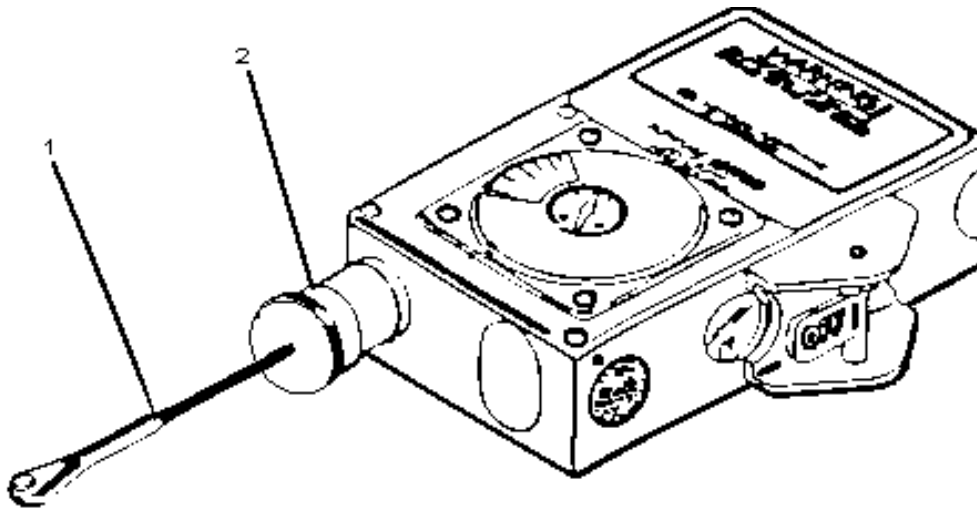

4280015P

COMPONENTS OF END ITEM LIST

(1) ILLUS NUMBER	(2) NATIONAL STOCK NUMBER	(3) DESCRIPTION, CAGEC, AND PART NUMBER	(4) USABLE ON CODE	(5) U/M	(6) QTY RQR
1	11-1-6923-1	CABLE, STORAGE (26309) 451-094		EA	1
2	1670-01-428-9252	CAP, PISTON ROD (26309) 451-205 (81337) 11-1-4053-1		EA	1

**AUTOMATIC RIPCORD RELEASE, MODEL 451
COMPONENTS OF END ITEMS (COEI) AND BASIC ISSUE ITEMS (BII) - CONT**

0036 00

BASIC ISSUE ITEMS (BII), AUTOMATIC RIPCORD RELEASE, MODEL 451

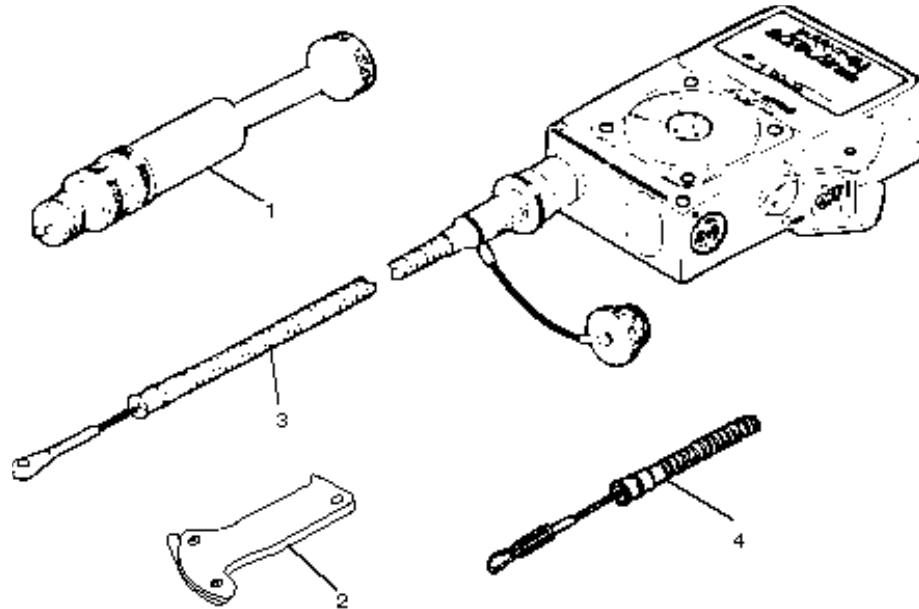

425-002P

BASIC ISSUE ITEMS LIST

(1) ILLUS NUMBER	(2) NATIONAL STOCK NUMBER	(3) DESCRIPTION, CAGEC, AND PART NUMBER	(4) USABLE ON CODE	(5) U/M	(6) QTY RQR
1	1670-01-428-7637	STROKE SIMULATOR, RIPCORD RELEASE (81337) 11-1-4054-1		EA	1
2		SLACK CHECKER (26309) 451-230-1		EA	1
3	6150-01-390-4709	POWER CABLE ASSY, MAIN RIPCORD RELEASE (81337) 11-1-6906-1		EA	1
4	6150-01-390-4711	POWER CABLE ASSY, RSV, RIPCORD RELEASE (81337) 11-1-6906-2		EA	1

TEST CHAMBER ASSEMBLY, MODEL 452
 COMPONENTS OF END ITEMS (COEI) AND BASIC ISSUE ITEMS (BII)

0037 00

COMPONENTS OF END ITEM (COEI), TEST CHAMBER ASSEMBLY, MODEL 452

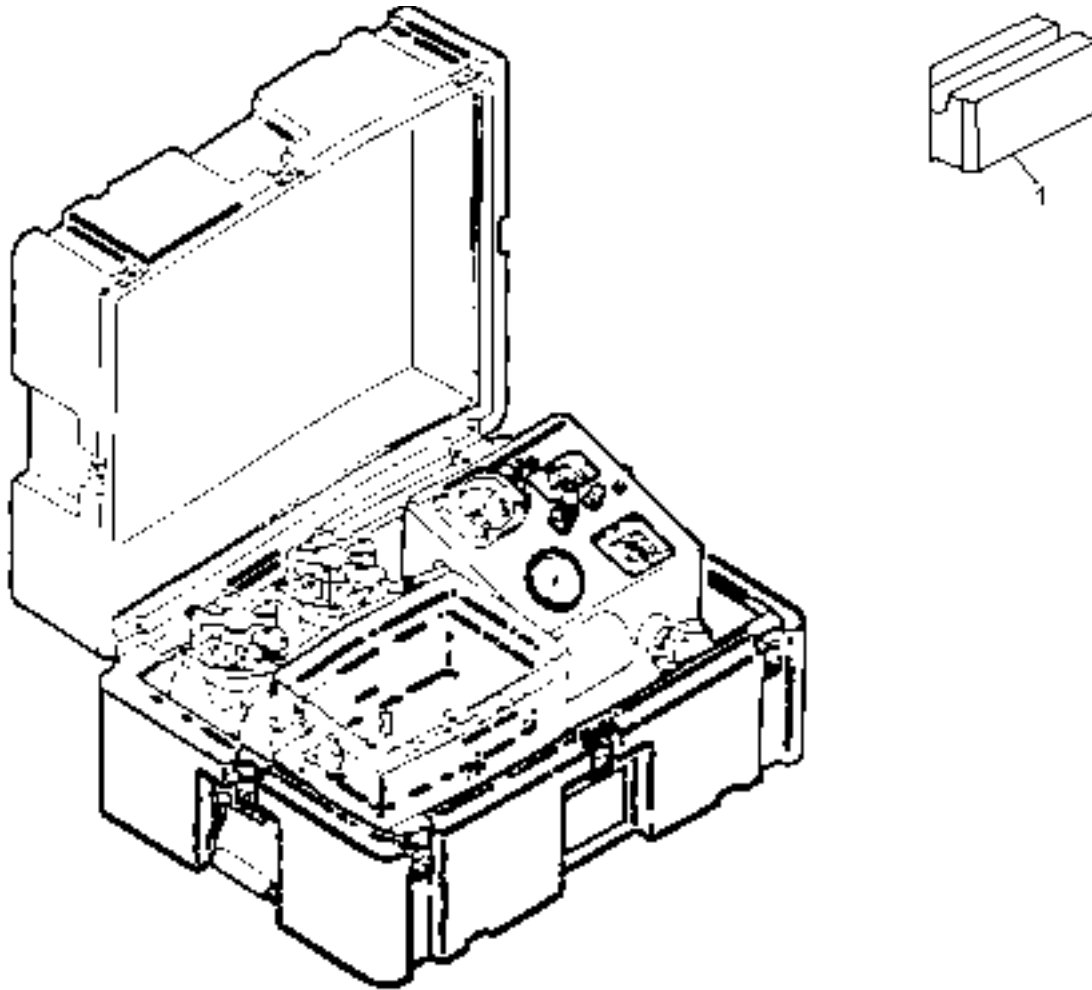

453-0024P

COMPONENTS OF END ITEM LIST

(1) ILLUS NUMBER	(2) NATIONAL STOCK NUMBER	(3) DESCRIPTION, CAGEC, AND PART NUMBER	(4) USABLE ON CODE	(5) UM	(6) QTYR QR
1		SUPPORT, COCKING (26309) 453-099		EA	1

**TEST CHAMBER ASSEMBLY, MODEL 452
COMPONENTS OF END ITEMS (COEI) AND BASIC ISSUE ITEMS (BII) – CONT**

0037 00

BASIC ISSUE ITEMS (BII), TEST CHAMBER ASSEMBLY, MODEL 452

There is no BII for the Test Chamber Assembly, Model 452.

**ELECTRONIC TEST CHAMBER ASSEMBLY, MODEL 453
COMPONENTS OF END ITEMS (COEI) AND BASIC ISSUE ITEMS (BII)**

0038 00

**COMPONENTS OF END ITEMS (COEI), ELECTRONIC TEST CHAMBER ASSEMBLY,
MODEL 453**

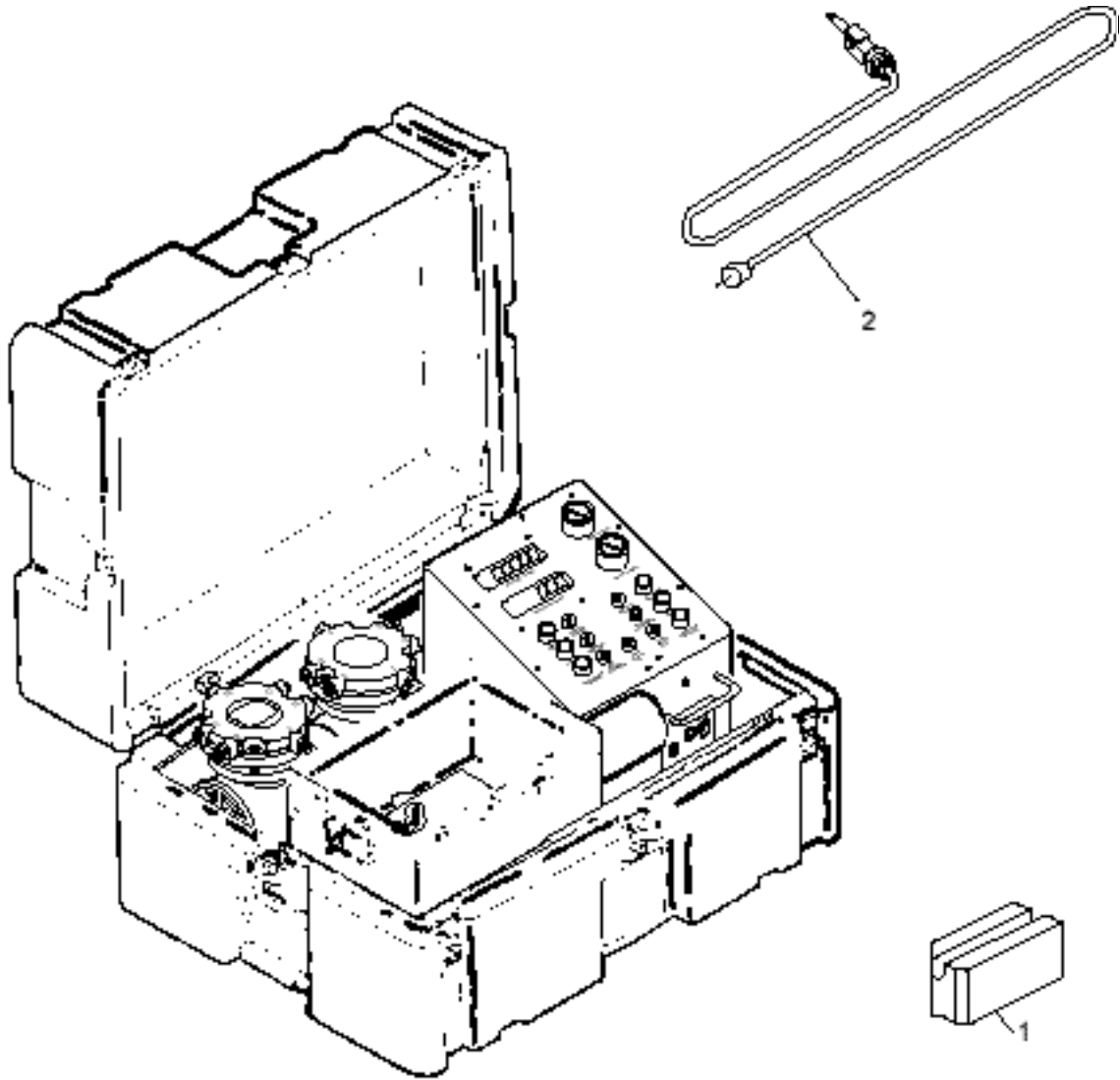

453-000 2P

COMPONENTS OF END ITEM LIST

(1) ILLUS NUMBER	(2) NATIONAL STOCK NUMBER	(3) DESCRIPTION, CAGEC, AND PART NUMBER	(4) USABLE ON CODE	(5) U/M	(6) QTYR QR
1		SUPPORT, COCKING (26309) 453-099		EA	1
2		ADAPTER, CALIBRATION (26309) 453-280		EA	1

MODEL 453 ELECTRONIC TEST CHAMBER ASSEMBLY
COMPONENTS OF END ITEMS (COEI) AND BASIC ISSUE ITEMS (BII) - CONT

0038 00

BASIC ISSUE ITEMS (BII) , ELECTRONIC TEST CHAMBER ASSEMBLY, MODEL 453

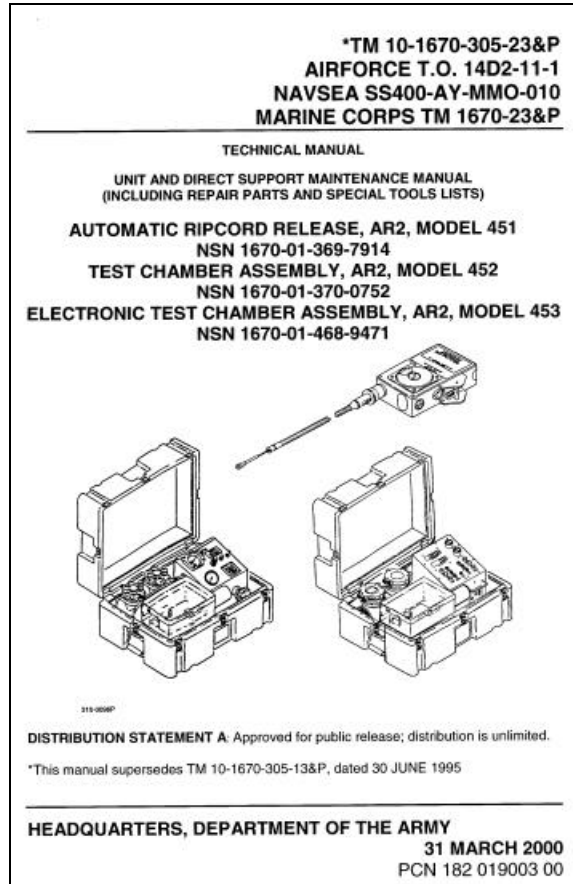

(1) ILLUS NUMBER	(2) NATIONAL STOCK NUMBER	(3) DESCRIPTION, CAGEC, AND PART NUMBER	(4) USABLE ON CODE	(5) U/M	(6) QTYR QR
1		TM 10-1670-305-23&P AIR FORCE T.O. 14D2-11-1 NAVSEA SS400-AY-MMO-010 MARINE CORPS TM 1670-23&P TECHNICAL MANUAL, UNIT AND DIRECT SUPPORT MAINTENANCE MANUAL (INCLUDING REPAIR PARTS AND SPECIAL TOOLS LIST), AUTOMATIC RIPCORD RELEASE, AR2, MODEL 451, TEST CHAMBER ASSEMBLY, AR2, MODEL 452, ELECTRONIC TEST CHAMBER ASSEMBLY, AR2, MODEL 453		EA	1

**ADDITIONAL AUTHORIZATION LIST (AAL)
INTRODUCTION**

0039 00

SCOPE

There is no Additional Authorization List for the Automatic Ripcord Release, Model 451, Test Chamber Assembly, Model 452, and Electronic Test Chamber Assembly, Model 453.

THIS PAGE INTENTIONALLY LEFT BLANK

**EXPENDABLE AND DURABLE ITEMS LIST
INTRODUCTION**

0040 00

SCOPE

This work package lists expendable and durable items that you will need to operate and maintain the AR2 Automatic Ripcord Release, Model 451, Test Chamber Assembly, Model 452, and Electronic Test Chamber Assembly, Model 453. This list is for information only and is not authority to requisition the listed items. These items are authorized to you by CTA 50-970. Expendable/Durable Items (Except Medical, Class V Repair Parts, and Heraldic items), or CTA 8-100, Army Medical Department Expendable/Durable items.

Explanations of columns in the Expendable/Durable Items List

Column (1)-Item Number. This number is assigned to the entry in the list and is referenced in the narrative instructions to identify the item (e.g., "Use desiccant (Item WP 0064 00).").

Column (2)-Level. This column includes the lowest level of maintenance that requires the listed item (C = Operator/Crew).

Column (3)-National Stock Number. This is the NSN assigned to the item which you can use to requisition it.

Column (4)-Item Name, Description, Commercial and Government Entity Code (CAGEC), and Part Number (P/N). This column provides the other information you need to identify the item.

Column (5)-Unit of Measure (U/M). This code shows the physical measurement or count of an item, such as gallon, dozen, gross, etc.

EXPENDABLE AND DURABLE ITEMS LIST

TABLE 1. EXPENDABLE AND DURABLE ITEMS LIST

(1) Item Number	(2) Level	(3) National Stock Number	(4) Description	(5) U/M
1	0	6810-00-753-4993	Isopropyl Alcohol (Anhydrous)	PT
2	0	MIL-G-27617	Lubricant, Antiseize	OZ
3	0	7920-00-044-9281	Cloth, Lint free, Cleaning	BX
4	0	9905-00-537-8954	Tag, Marker (64067)	EA

THIS PAGE INTENTIONALLY LEFT BLANK

TOOL IDENTIFICATION LIST

0041 00

This work package lists all common tools and supplements and special tools/fixtures needed to maintain the Automatic Ripcord Release, Model 451, Test Chamber Assembly, Model 452, and Electronic Test Chamber Assembly, Model 453.

EXPLANATION OF COLUMNS IN THE TOOL IDENTIFICATION LIST

- a. Column (1) – Item Number. This number is assigned to the entry in the list and is referenced in the initial setup to identify the item (e.g., “Extractor (item 32, WP 0105 00)”).
- b. Column (2) – Item Name. This column lists the item by noun nomenclature and other descriptive features (e.g., “Gage, belt tension”).
- c. Column (3) – National Stock Number. This is the National Stock Number (NSN) assigned to the item; use it to requisition the item.
- d. Column (4) – Part Number/CAGEC. Indicates the primary number used by the manufacturer (individual, company, firm, corporation, or Government activity) which controls the design and characteristics of the item by means of its engineering drawings, specifications, standards, and inspection requirements to identify an item of range of items. The manufacturer’s Commercial and Government Entity Code (CAGEC) is also included.
- e. Column (5) – Reference. This column identifies the authorizing supply catalog or RPSTL for items listed in this work package.

TOOL IDENTIFICATION LIST

(1) ITEM NO.	(2) ITEM NAME	(3) NATIONAL STOCK NUMBER	(4) PART NUMBER/ CAGEC	(5) REFERENCE
1	KNIFE			
2	MODEL 451 AUTOMATIC RIPCORDER RELEASE	1670-01-369-7914	11-1-6905-1	
3	MODEL 452 TEST CHAMBER ASSEMBLY	1670-01-370-0752	452-000	
4	MODEL 453 ELECTRONIC TEST CHAMBER ASSEMBLY	1670-01-468-9471	453-001	
5	NUTDRIVER, 3/8 INCH			
6	PUTTY KNIFE	5120-00-294-4605		
7	SCREWDRIVER, PHILLIPS, NO. 2	5120-00-234-8913		
8	SCREWDRIVER, PHILLIPS, NO. 2 x 7 INCH	5120-00-596-0861		
9	SCREWDRIVER, PHILLIPS, NO. 3	5120-00-234-8912		
10	SCREWDRIVER, SLOTTED, 3/32 INCH	5120-00-720-4969		
11	SCREWDRIVER, SLOTTED, 5/32 INCH			
12	SCREWDRIVER, SLOTTED, ¼ INCH	5120-00-596-9364		
13	SLACK CHECKER		451-230-1	
14	WRENCH, ADJUSTABLE, 6 INCH	5120-00-264-3795		
15	WRENCH, OPEN END, 5/8 INCH	5120-00-187-7126		
16	WRENCH, OPEN END, 11/16 INCH	5120-00-224-3160		

THIS PAGE INTENTIONALLY LEFT BLANK

AR2 MAINTENANCE LOG

0042 00

This work package provides a reproducible form to record the maintenance history in the AR2. Entries shall be in accordance with operation of either test set (WP 0009 00 or WP 0010 00).

SNS 1670-01-369-7914
S/N: _____

DATE AIS: _____

DATE OF TEST			
CUMULATIVE NO. OF JUMPS			
CUMULATIVE NO. OF ACTUATIONS			

NOTE: ACTUATION ALTITUDE TOLERANCES ± 300FT BELOW 10,000 FT;
± 500FT AT 10,000 FT OR ABOVE

CHECKS:

1ST: 5,500FT FIRE ALT _____ GO/NO GO 4TH: 3,000FT FIRE ALT _____ GO/NO GO
 2ND: 5,500FT NO FIRE _____ GO/NO GO 5TH: 8,000FT FIRE ALT _____ GO/NO GO
 3RD: 10,500 FT NO FIRE _____ GO/NO GO 6TH: 15,000FT FIRE ALT _____ GO/NO GO
 7TH: _____ FT FIRE ALT _____ GO/NO GO

REMARKS: _____

DATE: _____

INSP: _____

CHECKS:

1ST: 5,500FT FIRE ALT _____ GO/NO GO 4TH: 3,000FT FIRE ALT _____ GO/NO GO
 2ND: 5,500FT NO FIRE _____ GO/NO GO 5TH: 8,000FT FIRE ALT _____ GO/NO GO
 3RD: 10,500 FT NO FIRE _____ GO/NO GO 6TH: 15,000FT FIRE ALT _____ GO/NO GO
 7TH: _____ FT FIRE ALT _____ GO/NO GO

REMARKS: _____

DATE: _____

INSP: _____

CHECKS:

1ST: 5,500FT FIRE ALT _____ GO/NO GO 4TH: 3,000FT FIRE ALT _____ GO/NO GO
 2ND: 5,500FT NO FIRE _____ GO/NO GO 5TH: 8,000FT FIRE ALT _____ GO/NO GO
 3RD: 10,500 FT NO FIRE _____ GO/NO GO 6TH: 15,000FT FIRE ALT _____ GO/NO GO
 7TH: _____ FT FIRE ALT _____ GO/NO GO

REMARKS: _____

DATE: _____

INSP: _____

THIS PAGE INTENTIONALLY LEFT BLANK

INDEX

<u>Subject</u>	<u>WP Sequence No.-Page No.</u>
A	
Additional Authorization List (AAL) Introduction.....	0039 00-1
Scope	0039 00-1
AR2 Maintenance Log.....	0042 00-1
Automatic Ripcord Release, AR2 Jump/Off Switch Maintenance.	0020 00-1
Assembly and Installation of Jump/Off Switch.....	0020 00-2
General	0020 00-1
Initial Setup	0020 00-1
Materials.....	0020 00-1
Removal and Disassembly of Jump/Off Switch	0020 00-1
Tools.....	0020 00-1
Automatic Ripcord Release, Model 451 Components of End Items (COEI) And Basic Issue Items (BII).....	0036 00-1
Basic Issue Items (BII), Automatic Ripcord Release, Model 451	0036 00-2
Components of End Item (COEI) Automatic Ripcord Release, Model 451	0036 00-1
Automatic Ripcord Release, Model 451 Equipment Description and Data	0002 00-1
Capabilities and Features.....	0002 00-1
Differences Between Models	0002 00-3
Equipment Characteristics, Capabilities and Features Characteristics.....	0002 00-1
Equipment Data.....	0002 00-3
Location and Description of Major Components	0002 00-1
Automatic Ripcord Release, Model 451 Operation Under Usual Conditions.....	0008 00-1
Assembly and Preparation For Use	0008 00-1
Decals and Instruction Plates.....	0008 00-10
Operation Procedures	0008 00-5
Preparation For Movement	0008 00-10
Shelter Requirements.....	0008 00-1
Automatic Ripcord Release, Model 451 Repair Parts List	0030 00-1
Repair Parts And Special Tools List	0030 00-1
Automatic Ripcord Release, Model 451 Theory of Operation	0004 00-1

INDEX

<u>Subject</u>	<u>WP Sequence No.-Page No.</u>
C	
Components of End Items (COEI) and Basic Issue Items (BII)	
Introduction	0035 00-1
General.....	0035 00-1
Scope	0035 00-1
D	
Description and Use of Controls and Indicators.....	0007 00-1
Automatic Ripcord Release, Model 451	0007 00-1
Electronic Test Chamber Assembly, Model 453	0007 00-4
Test Chamber Assembly, Model 452.....	0007 00-2
E	
Electronic Test Chamber Assembly, Model 453 Components of End Item (COEI) And Basic Issue Items (BII).....	0038 00-1
Basic Issue Items (BII), Electronic Test Chamber Assembly, Model 453	0038 00-2
Components of End Item (COEI), Electronic Test Chamber Assembly, Model 453.....	0038 00-1
Electronic Test Chamber Assembly, Model 453 Direct Support Maintenance.....	0025 00-1
Altitude Accuracy Verification	0025 00-1
Calibration And Adjustment	0025 00-1
Rate Adjustment	0025 00-5
Zero Altitude Adjustment	0025 00-4
Electronic Test Chamber Assembly, Model 453 Operation Under Unusual Conditions (High Altitude Facilities).....	0012 00-1
Testing At High Altitudes	0012 00-1
Electronic Test Chamber Assembly (Model 453) Operation Under Usual Conditions.....	0010 00-1
Actuation Altitude Test	0010 00-12
Altitude Stability Test.....	0010 00-2
Assembly And Preparation For Use.....	0010 00-1
Control Interlocks Test	0010 00-8
Decals And Instruction Plates	0010 00-13

INDEX

<u>Subject</u>	<u>WP Sequence No.-Page No.</u>
Fall Rate Test.....	0010 00-5
Initial Adjustment Before Use.....	0010 00-1
Operating Procedure.....	0010 00-10
Preparation for Movement.....	0010 00-15
Rate Threshold (All Fire) Test.....	0010 00-11
Rate Threshold (No Fire) Test.....	0010 00-11
Siting Requirements.....	0010 00-1
Shelter Requirements.....	0010 00-1
Shutdown After Testing.....	0010 00-15
Electronic Test Chamber Assembly, Model 453 Repair Parts List	0032 00-1
Electronic Test Chamber Assembly, Model 453 Unit	
Maintenance.....	0022 00-1
Assembly.....	0022 00-6
Calibration.....	0022 00-7
Cleaning.....	0022 00-6
Disassembly.....	0022 00-2
General.....	0022 00-1
Initial Setup.....	0022 00-1
Inspection.....	0022 00-6
Inspection Prior To Disassembly.....	0022 00-1
Materials.....	0022 00-1
Tools.....	0022 00-1
Expendable And Durable Items List Introduction.....	0040 00-1
Expendable And Durable Items List.....	0040 00-1
Scope.....	0040 00-1

G

General Information.....	0001 00-1
Calibration.....	0001 00-3
Corrosion Prevention and Control (CPC).....	0001 00-2
Destruction of Army Material To Prevent Enemy Use.....	0001 00-2
List of Abbreviations.....	0001 00-2
Maintenance Forms, Records, And Reports.....	0001 00-1
Nomenclature Cross Reference List.....	0001 00-2

INDEX

<u>Subject</u>	<u>WP Sequence No.-Page No.</u>
Preparation For Storage or Shipment	0001 00-2
Reporting Equipment Improvement Recommendations (EIR)	0001 00-1
Safety, Care and Handling.....	0001 00-3
Scope	0001 00-1
Warranty Information.....	0001 00-2
M	
Maintenance Allocation Chart.....	0028 00-1
Automatic Ripcord Release Model 451	0028 00-1
Electronic Test Chamber Assembly, Model 453	0028 00-3
Test Chamber Assembly, Model 452	0028 00-2
Maintenance Allocation Chart (MAC).....	0027 00-1
Explanation of Columns in Remarks, Section IV.....	0027 00-4
Explanation of Columns in The MAC, Section II	0027 00-3
Explanation of Columns in Tools And Test Equipment Requirements, Section III	0027 00-4
Maintenance Functions	0027 00-1
The Army Maintenance System	0027 00-1
N	
National Stock Number Index.....	0033 00-1
P	
Part Number Index.....	0034 00-1
Power Cable Assembly, Main/Reserve Unit Maintenance.....	0019 00-1
Assembly of Power Cable Assembly	0019 00-4
Cleaning.....	0019 00-4
Disassembly of Power Cable Assembly	0019 00-3
General.....	0019 00-1
Initial Setup	0019 00-1
Inspection.....	0019 00-4
Inspection of Power Cable Assembly Prior to Disassembly ...	0019 00-2
Install Power Cable Assembly.....	0019 00-5
Materials.....	0019 00-1

INDEX

<u>Subject</u>	<u>WP Sequence No.-Page No.</u>
Removal of AR2 and Power Cable Assembly.....	0019 00-1
Tools.....	0019 00-1
Preliminary Checks And Adjustments.....	0017 00-1
Checks and Adjustments.....	0017 00-1
Controls and Indicators.....	0017 00-1
Preparation For Storage or Shipment.....	0023 00-1
Automatic Ripcord Release, Model 451, Preparation For Storage or Shipment Using Model 452 Test Chamber Assembly.....	0023 00-1
Preparation For Storage.....	0023 00-1
Storage.....	0023 00-2
Shipment.....	0023 00-2
Automatic Ripcord Release, Model 451, Preparation For Storage or Shipment Using Model 453 Electronic Test Chamber Assembly.....	0023 00-3
Preparation For Storage.....	0023 00-3
Storage.....	0023 00-4
Shipment.....	0023 00-4
Electronic Test Chamber Assembly, Model 453, Preparation For Storage or Shipment.....	0023 00-5
Storage.....	0023 00-6
Shipment.....	0023 00-6
Test Chamber Assembly, Model 452, Preparation For Storage or Shipment.....	0023 00-5
Storage.....	0023 00-5
Shipment.....	0023 00-5
Preventive Maintenance Checks and Services (PMCS).....	0018 00-1
Additional PMCS.....	0018 00-2
Additional PMCS.....	0018 00-3
Additional PMCS.....	0018 00-4
General.....	0018 00-1
Initial Setup.....	0018 00-1
Introduction.....	0018 00-1
Maintenance Level.....	0018 00-1
PMCS.....	0018 00-2
PMCS.....	0018 00-3

INDEX

<u>Subject</u>	<u>WP Sequence No.-Page No.</u>
PMCS	0018 00-4
R	
References.....	0026 00-1
Scope	0026 00-1
Repair Parts And Special Tool List (RPSTC).....	0029 00-1
Explanation of Columns in The Repair Parts List And Special Tools List Work Packages	0029 00-1
Explanation of Cross-Reference Indexes Work Packages Format and Columns.....	0029 00-6
General.....	0029 00-1
Index Numbers.....	0029 00-7
Scope	0029 00-1
Source Code	0029 00-2
Special Information	0029 00-7
S	
Service Upon Receipt.....	0016 00-1
Automatic Ripcord Release, Model 451	0016 00-1
Service Upon Receipt, Test Chamber Assembly Model 452..	0016 00-2
Service Upon Receipt, Electronic Test Chamber Assembly, Model 453	0016 00-2
Supporting Data For Repair Parts, Special Tools, TMDE and Support Equipment.....	0006 00-1
Repair Parts	0006 00-1
Special Tools, TMDE and Support Equipment.....	0006 00-1
T	
Test Chamber Assembly Equipment Description and Data	0003 00-1
Equipment Characteristics and Features	0003 00-1
Equipment Data (Model 452)	0003 00-6
Equipment Data (Model 453)	0003 00-7
Location and Description of Major Components (Model 452).	0003 00-1
Location and Description of Major Components (Model 453).	0003 00-3
Test Chamber Assembly, Model 452, Components of End Items (COEI) and Basic Issue Items (BII)	0037 00-1
Components of End Items (COEI), Test Chamber Assembly,	

INDEX

<u>Subject</u>	<u>WP Sequence No.-Page No.</u>
Model 452	0037 00-1
Basic Issue Items (BII) , Test Chamber Assembly, Model 452	0037 00-2
Test Chamber Assembly, Model 452, Direct Support Maintenance.....	0024 00-1
Calibration.....	0024 00-1
Test Chamber Assembly, Model 452 Operation Under Unusual Conditions (High Altitude Facilities)	0011 00-1
Testing At High Altitudes	0011 00-1
Test Chamber Assembly, Model 452 Operating Under Usual Conditions.....	0009 00-1
Assembly Preparation For Use	0009 00-1
Decals And Instruction Plates	0009 00-10
Initial Adjustment Before Use.....	0009 00-1
Operating Procedure.....	0009 00-6
Preparation For Movement	0009 00-13
Siting Requirements.....	0009 00-1
Shelter Requirements.....	0009 00-1
Test Chamber Assembly, Model 452 Repair Parts List	0031 00-1
Test Chamber Assembly, Model 452 Unit Maintenance.....	0021 00-1
Altimeter Calibration.....	0021 00-5
Assembly	0021 00-6
Cleaning.....	0021 00-5
Disassembly	0021 00-2
General	0021 00-1
Initial Setup	0021 00-1
Inspection.....	0021 00-5
Inspection Prior to Disassembly	0021 00-1
Materials	0021 00-1
Tools.....	0021 00-1
Test Chamber Assembly Theory of Operation.....	0005 00-1
Theory of Operation (Model 452)	0005 00-1
Theory of Operation (Model 453)	0005 00-4
Tool Identification List.....	0041 00-1
Explanation of Columns in The Tool Identification List	0041 00-1
Tool Identification List.....	0041 00-1

INDEX

<u>Subject</u>	<u>WP Sequence No.-Page No.</u>
Trouble Shooting Procedures, General Information	0013 00-1
Scope of Task.....	0013 00-1
Trouble Shooting Procedures	0014 00-1
Initial Setup Information.....	0014 00-1
Trouble Shooting Procedures	0015 00-1
Initial Setup Information.....	0015 00-1

By Order of the Secretaries of the Army, Air Force, and Navy (Including the Marine Corps):

By Order of the Secretary of the Army:

Official:

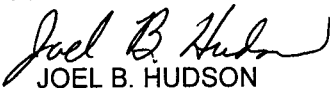
JOEL B. HUDSON
*Administrative Assistant to the
Secretary of the Army*
0017208

ERIC K. SHINSEKI
*General, United States Army
Chief of Staff*

MICHAEL E. RYAN
*General, USAF
Chief of Staff*

Official:

LESTER L. LYLES.
*General, USAF
Commander, Air Force Materiel Command*

D.G. MORRAL
*Rear Admiral, USN
Program Executive Officer
For Expeditionary Warfare
Naval Sea Systems Command*

G. N. GEORGEADIS
*Director, Program Support
Marine Corps Systems Command*

DISTRIBUTION:

To be distributed in accordance with initial distribution (IND 256621), requirements for TM 10-1670-305-23&P.

THIS PAGE INTENTIONALLY LEFT BLANK

These are the instructions for sending an electronic 2028

The following format must be used if submitting an electronic 2028. The subject line must be exactly the same and all fields must be included; however only the following fields are mandatory: 1, 3, 4, 5, 6, 7, 8, 9, 10, 13, 15, 16, 17, and 27.

From: "Whomever" <whomever@avma27.army.mil>

To: amssb-rim-e@natick.army.mil

Subject: DA Form 2028

1. **From:** Joe Smith
2. **Unit:** home
3. **Address:** 4300 Park
4. **City:** Hometown
5. **St:** MO
6. **Zip:** 77777
7. **Date Sent:** 19-OCT-93
8. **Pub no:** 55-2840-229-23
9. **Pub Title:** TM
10. **Publication Date:** 04-JUL-85
11. **Change Number:** 7
12. **Submitter Rank:** MSG
13. **Submitter FName:** Joe
14. **Submitter MName:** T
15. **Submitter LName:** Smith
16. **Submitter Phone:** 123-123-1234
17. **Problem:** 1
18. **Page:** 2
19. **Paragraph:** 3
20. **Line:** 4
21. **NSN:** 5
22. **Reference:** 6
23. **Figure:** 7
24. **Table:** 8
25. **Item:** 9
26. **Total:** 123
27. **Text:**

This is the text for the problem below line 27.

THIS PAGE INTENTIONALLY LEFT BLANK



THEN . . . JOT DOWN THE DOPE ABOUT IT ON THIS FORM, CAREFULLY TEAR IT OUT, FOLD IT AND DROP IT IN THE MAIL!

SOMETHING WRONG WITH THIS PUBLICATION?

FROM: (PRINT YOUR UNIT'S COMPLETE ADDRESS)

*PFC John DOE
CO A 3rd Engineer Bn
Ft. Leonardwood, MO 63108*

DATE SENT

22 August 1992

PUBLICATION NUMBER

TM 1-1520-250-10

PUBLICATION DATE

15 June 1992

PUBLICATION TITLE

Operator's manual MH60K Helicopter

BE EXACT PIN-POINT WHERE IT IS

IN THIS SPACE, TELL WHAT IS WRONG AND WHAT SHOULD BE DONE ABOUT IT:

PAGE NO	PARA-GRAPH	FIGURE NO	TABLE NO
6	2-1 a		
B1		4-3	

In line 6 of paragraph 2-1a the manual states the engine has 6 cylinders. The engine on my set only has 4 cylinders. Change the manual to show 4 cylinders.

Callout 16 on figure 4-3 is pointed at a bolt. In key to figure 4-3, item 16 is called a shim. Please correct one or the other

PRINTED NAME, GRADE OR TITLE, AND TELEPHONE NUMBER

JOHN DOE, PFC (268) 317-7111

SIGN HERE

JOHN DOE John Doe

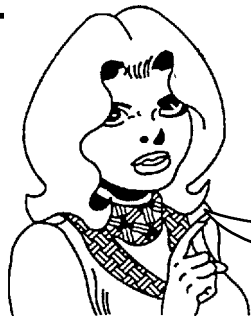

THEN . . . JOT DOWN THE DOPE ABOUT IT ON THIS FORM, CAREFULLY TEAR IT OUT, FOLD IT AND DROP IT IN THE MAIL!

SOMETHING WRONG WITH THIS PUBLICATION?

FROM: (PRINT YOUR UNIT'S COMPLETE ADDRESS)

DATE SENT

PUBLICATION NUMBER
TM 10-1670-305-23&P

PUBLICATION DATE
21 JUNE 2000

PUBLICATION TITLE
Automatic Ripcord Release AR2

BE EXACT PIN-POINT WHERE IT IS IN THIS SPACE, TELL WHAT IS WRONG AND WHAT SHOULD BE DONE ABOUT IT:

PAGE NO	PARA-GRAPH	FIGURE NO	TABLE NO

PRINTED NAME, GRADE OR TITLE, AND TELEPHONE NUMBER

SIGN HERE

FILL IN YOUR
UNITS ADDRESS



FOLD BACK

DEPARTMENT OF THE ARMY

OFFICIAL BUSINESS

COMMANDER
U.S. ARMY SOLDIER SYSTEMS COMMAND
ATTN: AMSSB-RIM-E(N)
KANSAS STREET
NATICK, MA 91760-5000

TEAR ALONG PERFORATED LINE

The Metric System and Equivalents

Linear Measure

1 centimeter = 10 millimeters = .39 inch
 1 decimeter = 10 centimeters = 3.94 inches
 1 meter = 10 decimeters = 39.37 inches
 1 dekameter = 10 meters = 32.8 feet
 1 hectometer = 10 dekameters = 328.08 feet
 1 kilometer = 10 hectometers = 3,280.8 feet

Weights

1 centigram = 10 milligrams = .15 grain
 1 decigram = 10 centigrams = 1.54 grains
 1 gram = 10 decigrams = .035 ounce
 1 dekagram = 10 grams = .35 ounce
 1 hectogram = 10 dekagrams = 3.52 ounces
 1 kilogram = 10 hectograms = 2.2 pounds
 1 quintal = 100 kilograms = 220.46 pounds
 1 metric ton = 10 quintals = 1.1 short tons

Liquid Measure

1 centiliter = 10 milliliters = .34 fl. ounce
 1 deciliter = 10 centiliters = 3.38 fl. ounces
 1 liter = 10 deciliters = 33.81 fl. ounces
 1 dekaliter = 10 liters = 2.64 gallons
 1 hectoliter = 10 dekaliters = 26.42 gallons
 1 kiloliter = 10 hectoliters = 264.18 gallons

Square Measure

1 sq. centimeter = 100 sq. millimeters = .155 sq. inch
 1 sq. decimeter = 100 sq. centimeters = 15.5 sq. inches
 1 sq. meter (centare) = 100 sq. decimeters = 10.76 sq. feet
 1 sq. dekameter (are) = 100 sq. meters = 1,076.4 sq. feet
 1 sq. hectometer (hectare) = 100 sq. dekameters = 2.47 acres
 1 sq. kilometer = 100 sq. hectometers = .386 sq. mile

Cubic Measure

1 cu. centimeter = 1000 cu. millimeters = .06 cu. inch
 1 cu. decimeter = 1000 cu. centimeters = 61.02 cu. inches
 1 cu. meter = 1000 cu. decimeters = 35.31 feet

Approximate Conversion Factors

<i>To change</i>	<i>To</i>	<i>Multiply by</i>	<i>To change</i>	<i>To</i>	<i>Multiply by</i>
inches	centimeters	2.540	ounce-inches	newton-meters	.007062
feet	meters	.305	centimeters	inches	.394
yards	meters	.914	meters	feet	3.280
miles	kilometers	1.609	meters	yards	1.094
square inches	square centimeters	6.451	kilometers	miles	.621
square feet	square meters	.093	square centimeters	square inches	.155
square yards	square meters	.836	square meters	square feet	10.764
square miles	square kilometers	2.590	square meters	square yards	1.196
acres	square hectometers	.405	square kilometers	square miles	.386
cubic feet	cubic meters	.028	square hectometers	acres	2.471
cubic yards	cubic meters	.765	cubic meters	cubic feet	35.315
fluid ounces	milliliters	29.573	cubic meters	cubic yards	1.308
pints	liters	.473	milliliters	fluid ounces	.034
quarts	liters	.946	liters	pints	2.113
gallons	liters	3.785	liters	quarts	1.057
ounces	grams	28.349	liters	gallons	.264
pounds	kilograms	.454	grams	ounces	.035
short tons	metric tons	.907	kilograms	pounds	2.205
pound-feet	newton-meters	1.356	metric tons	short tons	1.102
pound-inches	newton-meters	.11296			

Temperature (Exact)

_F	Fahrenheit temperature	5/9 (after subtracting 32)	Celsius temperature	_C
----	---------------------------	-------------------------------	------------------------	----

PIN: 078216-000